

# Photosynthesis

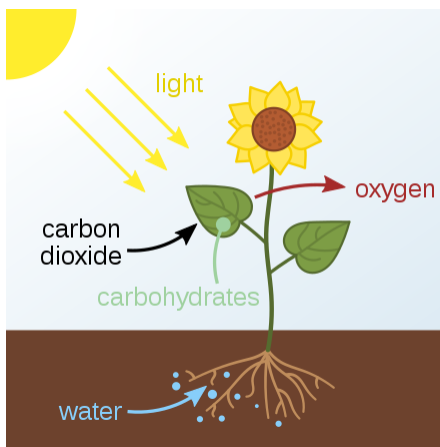

*Schematic of photosynthesis in plants. The carbohydrates produced are stored in or used by the plant.*

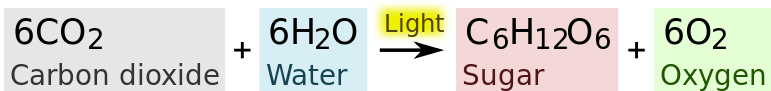

*Overall equation for the type of photosynthesis that occurs in plants*

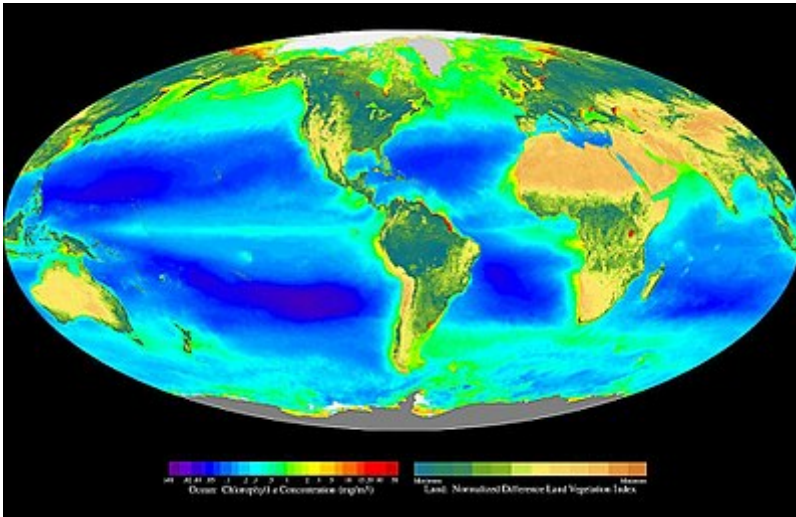

*Composite image showing the global distribution of photosynthesis, including both oceanic phytoplankton and terrestrial vegetation. Dark red and blue-green indicate regions of high photosynthetic activity in the ocean and on land, respectively.*

**Photosynthesis** is a process used by plants and other organisms to convert light energy into chemical energy that can

later be released to fuel the organisms' activities. This chemical energy is stored in carbohydrate molecules, such as sugars, which are synthesized from carbon dioxide and water – hence the name *photosynthesis*, from the Greek *phōs* (φῶς), "light", and *sunthesis* (σύνθεσις), "putting together".<sup>[1][2][3]</sup> In most cases, oxygen is also released as a waste product. Most plants, most algae, and cyanobacteria perform photosynthesis; such organisms are called photoautotrophs. Photosynthesis is largely responsible for producing and maintaining the oxygen content of the Earth's

atmosphere, and supplies most of the energy necessary for life on Earth.<sup>[4]</sup>

Although photosynthesis is performed differently by different species, the process always begins when energy from light is absorbed by proteins called reaction centres that contain green chlorophyll pigments. In plants, these proteins are held inside organelles called chloroplasts, which are most abundant in leaf cells, while in bacteria they are embedded in the plasma membrane. In these light-dependent reactions, some energy is used to strip electrons from suitable substances, such as water,

producing oxygen gas. The hydrogen freed by the splitting of water is used in the creation of two further compounds that serve as short-term stores of energy, enabling its transfer to drive other reactions: these compounds are reduced nicotinamide adenine dinucleotide phosphate (NADPH) and adenosine triphosphate (ATP), the "energy currency" of cells.

In plants, algae and cyanobacteria, long-term energy storage in the form of sugars is produced by a subsequent sequence of light-independent reactions called the Calvin cycle; some bacteria use different

mechanisms, such as the reverse Krebs cycle, to achieve the same end. In the Calvin cycle, atmospheric carbon dioxide is incorporated into already existing organic carbon compounds, such as ribulose biphosphate (RuBP).<sup>[5]</sup> Using the ATP and NADPH produced by the light-dependent reactions, the resulting compounds are then reduced and removed to form further carbohydrates, such as glucose.

The first photosynthetic organisms probably evolved early in the evolutionary history of life and most likely used reducing agents such as hydrogen or

hydrogen sulfide, rather than water, as sources of electrons.<sup>[6]</sup> Cyanobacteria appeared later; the excess oxygen they produced contributed directly to the oxygenation of the Earth,<sup>[7]</sup> which rendered the evolution of complex life possible.

Today, the average rate of energy capture by photosynthesis globally is approximately 130 terawatts,<sup>[8][9][10]</sup> which is about eight times the current power consumption of human civilization.<sup>[11]</sup>

Photosynthetic organisms also convert around 100–115 billion tons (91-104 petagrams) of carbon into biomass per year.<sup>[12][13]</sup>

# Overview

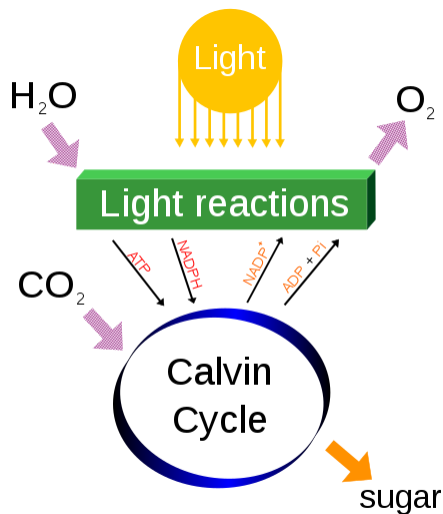

*Photosynthesis changes sunlight into chemical energy, splits water to liberate O<sub>2</sub>, and fixes CO<sub>2</sub> into sugar.*

Photosynthetic organisms are photoautotrophs, which means that they are able to synthesize food directly from carbon dioxide and water using energy from light. However, not all organisms use



carbon dioxide as a source of carbon atoms to carry out photosynthesis; photoheterotrophs use organic compounds, rather than carbon dioxide, as a source of carbon.<sup>[4]</sup> In plants, algae, and cyanobacteria, photosynthesis releases oxygen. This is called **oxygenic photosynthesis** and is by far the most common type of photosynthesis used by living organisms. Although there are some differences between oxygenic photosynthesis in plants, algae, and cyanobacteria, the overall process is quite similar in these organisms. There are also many varieties of anoxygenic photosynthesis, used mostly by certain

types of bacteria, which consume carbon dioxide but do not release oxygen.

Carbon dioxide is converted into sugars in a process called carbon fixation; photosynthesis captures energy from sunlight to convert carbon dioxide into carbohydrate. Carbon fixation is an endothermic redox reaction. In general outline, photosynthesis is the opposite of cellular respiration: while photosynthesis is a process of reduction of carbon dioxide to carbohydrate, cellular respiration is the oxidation of carbohydrate or other nutrients to carbon dioxide. Nutrients used in cellular respiration include

carbohydrates, amino acids and fatty acids. These nutrients are oxidized to produce carbon dioxide and water, and to release chemical energy to drive the organism's metabolism. Photosynthesis and cellular respiration are distinct processes, as they take place through different sequences of chemical reactions and in different cellular compartments.

The general equation for photosynthesis as first proposed by Cornelis van Niel is therefore:<sup>[14]</sup>

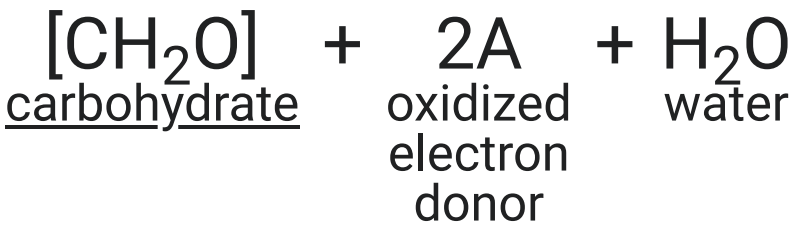
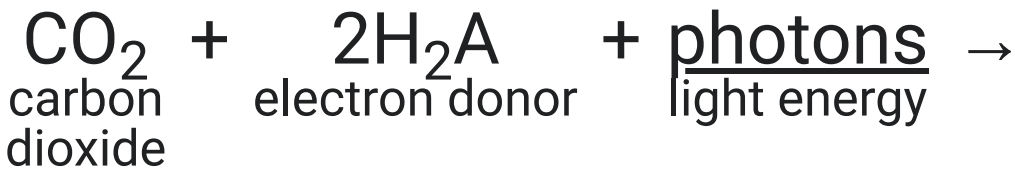

Since water is used as the electron donor in oxygenic photosynthesis, the equation for this process is:

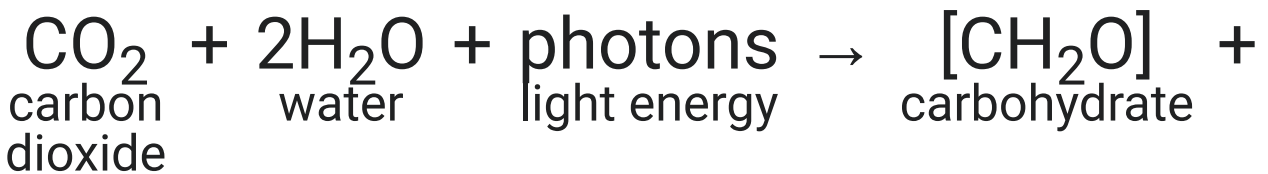

This equation emphasizes that water is both a reactant in the light-dependent reaction and a product of the light-independent reaction, but canceling  $n$

water molecules from each side gives the net equation:

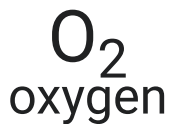
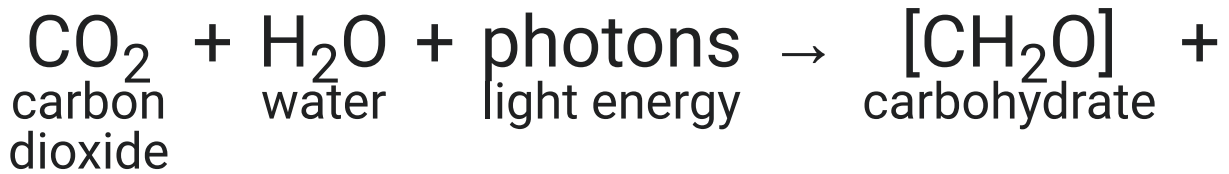

Other processes substitute other compounds (such as arsenite) for water in the electron-supply role; for example some microbes use sunlight to oxidize arsenite to arsenate.<sup>[15]</sup> The equation for this reaction is:



CO (used to build other compounds  
carbon  
monoxide

in subsequent reactions)<sup>[16]</sup>

Photosynthesis occurs in two stages. In the first stage, *light-dependent reactions* or *light reactions* capture the energy of light and use it to make the energy-storage molecules ATP and NADPH. During the second stage, the *light-independent reactions* use these products to capture and reduce carbon dioxide.

Most organisms that utilize oxygenic photosynthesis use visible light for the

light-dependent reactions, although at least three use shortwave infrared or, more specifically, far-red radiation.<sup>[17]</sup>

Some organisms employ even more radical variants of photosynthesis. Some archaea use a simpler method that employs a pigment similar to those used for vision in animals. The bacteriorhodopsin changes its configuration in response to sunlight, acting as a proton pump. This produces a proton gradient more directly, which is then converted to chemical energy. The process does not involve carbon dioxide fixation and does not release oxygen, and

seems to have evolved separately from the more common types of photosynthesis. [18][19]

# Photosynthetic membranes and organelles

---

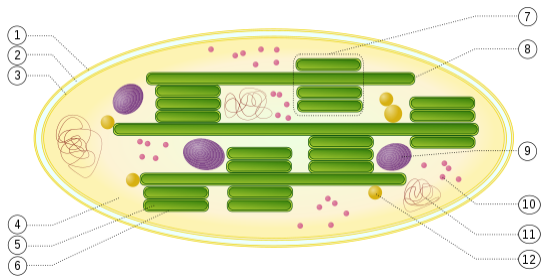

## ***Chloroplast ultrastructure:***

- 1. outer membrane*
- 2. intermembrane space*
- 3. inner membrane (1+2+3: envelope)*
- 4. stroma (aqueous fluid)*
- 5. thylakoid lumen (inside of thylakoid)*
- 6. thylakoid membrane*
- 7. granum (stack of thylakoids)*



8. *thylakoid (lamella)*
9. *starch*
10. *ribosome*
11. *plastidial DNA*
12. *plastoglobule (drop of lipids)*

In photosynthetic bacteria, the proteins that gather light for photosynthesis are embedded in cell membranes. In its simplest form, this involves the membrane surrounding the cell itself.<sup>[20]</sup> However, the membrane may be tightly folded into cylindrical sheets called thylakoids,<sup>[21]</sup> or bunched up into round vesicles called *intracytoplasmic membranes*.<sup>[22]</sup> These structures can fill most of the interior of a

cell, giving the membrane a very large surface area and therefore increasing the amount of light that the bacteria can absorb.<sup>[21]</sup>

In plants and algae, photosynthesis takes place in organelles called chloroplasts. A typical plant cell contains about 10 to 100 chloroplasts. The chloroplast is enclosed by a membrane. This membrane is composed of a phospholipid inner membrane, a phospholipid outer membrane, and an intermembrane space. Enclosed by the membrane is an aqueous fluid called the stroma. Embedded within the stroma are stacks of thylakoids

(grana), which are the site of photosynthesis. The thylakoids appear as flattened disks. The thylakoid itself is enclosed by the thylakoid membrane, and within the enclosed volume is a lumen or thylakoid space. Embedded in the thylakoid membrane are integral and peripheral membrane protein complexes of the photosynthetic system.

Plants absorb light primarily using the pigment chlorophyll. The green part of the light spectrum is not absorbed but is reflected which is the reason that most plants have a green color. Besides chlorophyll, plants also use pigments such

as carotenes and xanthophylls.<sup>[23]</sup> Algae also use chlorophyll, but various other pigments are present, such as phycocyanin, carotenes, and xanthophylls in green algae, phycoerythrin in red algae (rhodophytes) and fucoxanthin in brown algae and diatoms resulting in a wide variety of colors.

These pigments are embedded in plants and algae in complexes called antenna proteins. In such proteins, the pigments are arranged to work together. Such a combination of proteins is also called a light-harvesting complex.<sup>[24]</sup>

Although all cells in the green parts of a plant have chloroplasts, the majority of those are found in specially adapted structures called leaves. Certain species adapted to conditions of strong sunlight and aridity, such as many Euphorbia and cactus species, have their main photosynthetic organs in their stems. The cells in the interior tissues of a leaf, called the mesophyll, can contain between 450,000 and 800,000 chloroplasts for every square millimeter of leaf. The surface of the leaf is coated with a water-resistant waxy cuticle that protects the leaf from excessive evaporation of water and decreases the absorption of ultraviolet

or blue light to reduce heating. The transparent epidermis layer allows light to pass through to the palisade mesophyll cells where most of the photosynthesis takes place.

## Light-dependent reactions

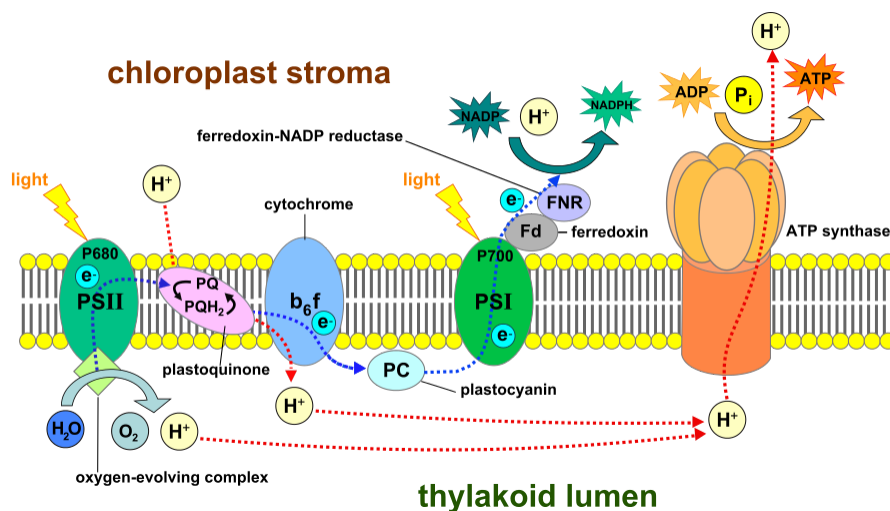

*Light-dependent reactions of photosynthesis at the thylakoid membrane*

In the light-dependent reactions, one molecule of the pigment chlorophyll absorbs one photon and loses one electron. This electron is passed to a modified form of chlorophyll called pheophytin, which passes the electron to a quinone molecule, starting the flow of electrons down an electron transport chain that leads to the ultimate reduction of NADP to NADPH. In addition, this creates a proton gradient (energy gradient) across the chloroplast membrane, which is used by ATP synthase in the synthesis of ATP. The chlorophyll molecule ultimately regains the electron it lost when a water molecule is split in a process called

photolysis, which releases a dioxygen (O<sub>2</sub>) molecule as a waste product.

The overall equation for the light-dependent reactions under the conditions of non-cyclic electron flow in green plants is:<sup>[25]</sup>

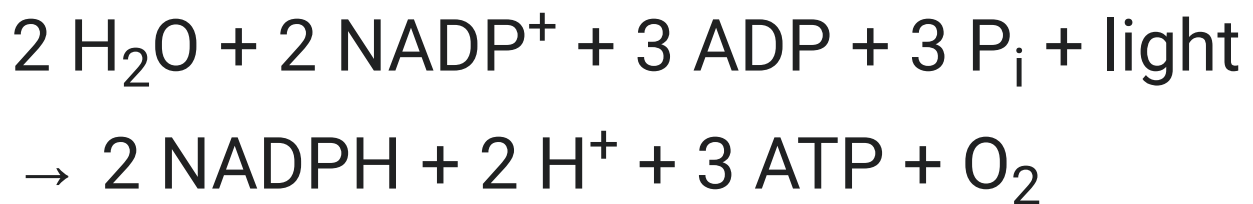

Not all wavelengths of light can support photosynthesis. The photosynthetic action spectrum depends on the type of accessory pigments present. For example, in green plants, the action spectrum resembles the absorption spectrum for



chlorophylls and carotenoids with absorption peaks in violet-blue and red light. In red algae, the action spectrum is blue-green light, which allows these algae to use the blue end of the spectrum to grow in the deeper waters that filter out the longer wavelengths (red light) used by above ground green plants. The non-absorbed part of the light spectrum is what gives photosynthetic organisms their color (e.g., green plants, red algae, purple bacteria) and is the least effective for photosynthesis in the respective organisms.

# Z scheme

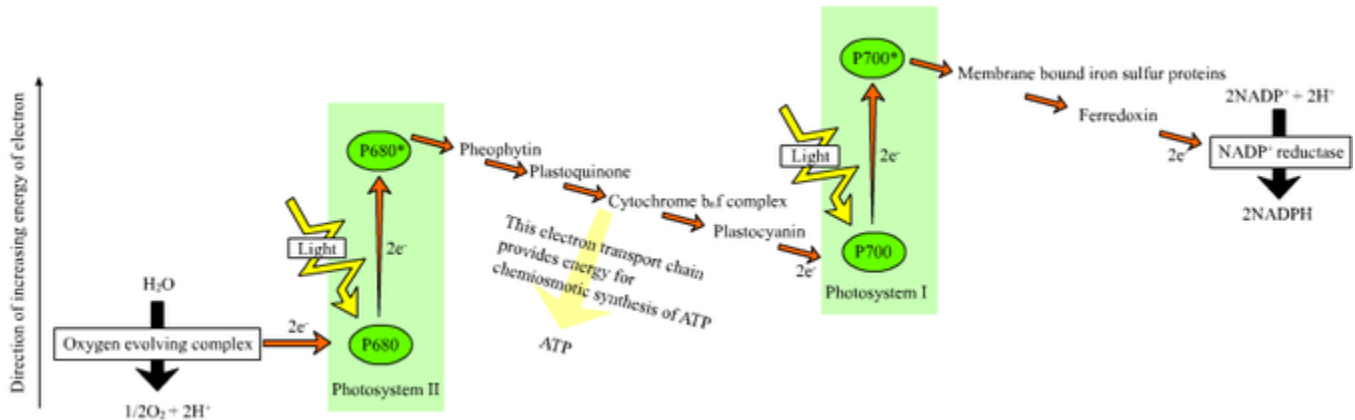

*The "Z scheme"*

In plants, light-dependent reactions occur in the thylakoid membranes of the chloroplasts where they drive the synthesis of ATP and NADPH. The light-dependent reactions are of two forms: cyclic and non-cyclic.

In the non-cyclic reaction, the photons are captured in the light-harvesting antenna complexes of photosystem II by chlorophyll and other accessory pigments (see diagram at right). The absorption of a photon by the antenna complex frees an electron by a process called photoinduced charge separation. The antenna system is at the core of the chlorophyll molecule of the photosystem II reaction center. That freed electron is transferred to the primary electron-acceptor molecule, pheophytin. As the electrons are shuttled through an electron transport chain (the so-called *Z-scheme* shown in the diagram), it initially functions to generate a chemiosmotic

potential by pumping proton cations ( $H^+$ ) across the membrane and into the thylakoid space. An ATP synthase enzyme uses that chemiosmotic potential to make ATP during photophosphorylation, whereas NADPH is a product of the terminal redox reaction in the *Z-scheme*. The electron enters a chlorophyll molecule in Photosystem I. There it is further excited by the light absorbed by that photosystem. The electron is then passed along a chain of electron acceptors to which it transfers some of its energy. The energy delivered to the electron acceptors is used to move hydrogen ions across the thylakoid membrane into the lumen. The

electron is eventually used to reduce the co-enzyme NADP with a  $H^+$  to NADPH (which has functions in the light-independent reaction); at that point, the path of that electron ends.

The cyclic reaction is similar to that of the non-cyclic, but differs in that it generates only ATP, and no reduced NADP (NADPH) is created. The cyclic reaction takes place only at photosystem I. Once the electron is displaced from the photosystem, the electron is passed down the electron acceptor molecules and returns to photosystem I, from where it was emitted, hence the name *cyclic reaction*.

# Water photolysis

Linear electron transport through a photosystem will leave the reaction center of that photosystem oxidized. Elevating another electron will first require re-reduction of the reaction center. The excited electrons lost from the reaction center (P700) of photosystem I are replaced by transfer from plastocyanin, whose electrons come from electron transport through photosystem II.

Photosystem II, as the first step of the *Z-scheme*, requires an external source of electrons to reduce its oxidized chlorophyll a reaction center, called P680. The source

of electrons for photosynthesis in green plants and cyanobacteria is water. Two water molecules are oxidized by four successive charge-separation reactions by photosystem II to yield a molecule of diatomic oxygen and four hydrogen ions. The electrons yielded are transferred to a redox-active tyrosine residue that then reduces the oxidized P680. This resets the ability of P680 to absorb another photon and release another photo-dissociated electron. The oxidation of water is catalyzed in photosystem II by a redox-active structure that contains four manganese ions and a calcium ion; this oxygen-evolving complex binds two water

molecules and contains the four oxidizing equivalents that are used to drive the water-oxidizing reaction (Dolai's S-state diagrams). Photosystem II is the only known biological enzyme that carries out this oxidation of water. The hydrogen ions are released in the thylakoid lumen and therefore contribute to the transmembrane chemiosmotic potential that leads to ATP synthesis. Oxygen is a waste product of light-dependent reactions, but the majority of organisms on Earth use oxygen for cellular respiration, including photosynthetic organisms. <sup>[26]</sup><sup>[27]</sup>

## Light-independent reactions



# Calvin cycle

In the light-independent (or "dark") reactions, the enzyme RuBisCO captures CO<sub>2</sub> from the atmosphere and, in a process called the Calvin cycle, it uses the newly formed NADPH and releases three-carbon sugars, which are later combined to form sucrose and starch. The overall equation for the light-independent reactions in green plants is<sup>[25]:128</sup>

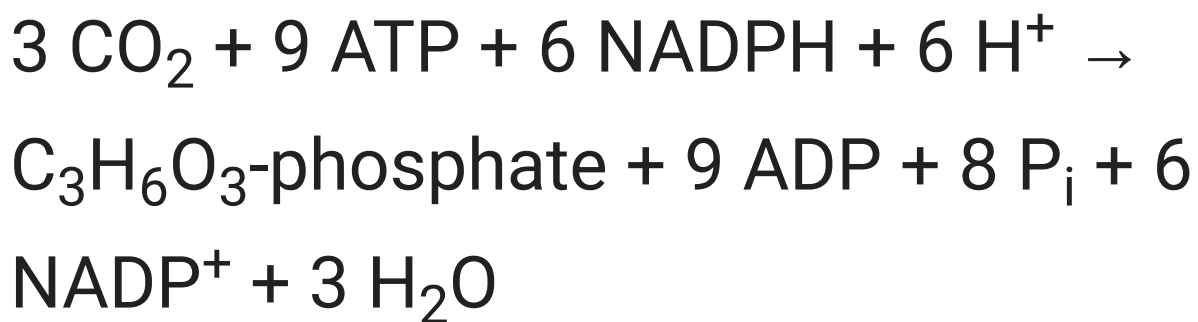

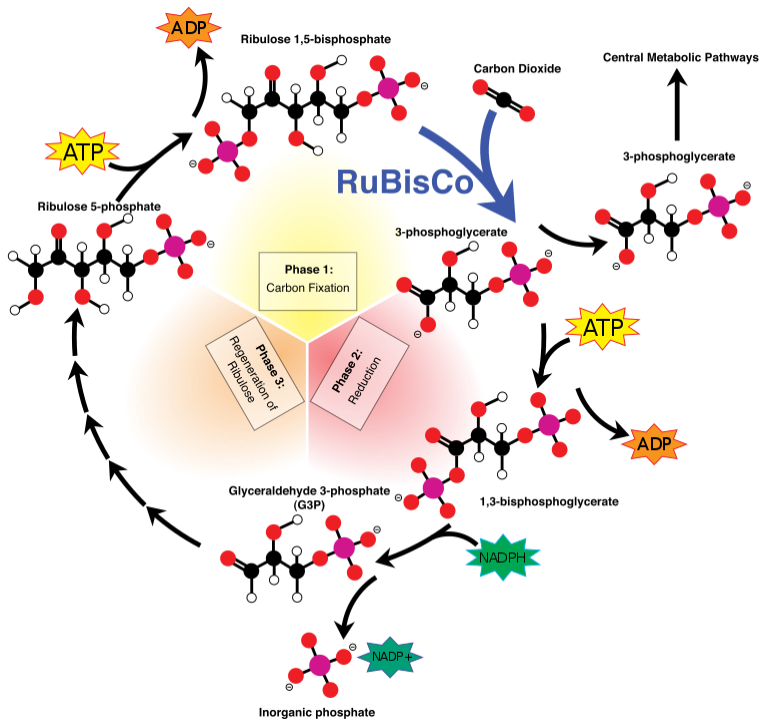

## *Overview of the Calvin cycle and carbon fixation*

Carbon fixation produces the intermediate three-carbon sugar product, which is then converted into the final carbohydrate products. The simple carbon sugars produced by photosynthesis are then used in the forming of other organic compounds, such as the building material

cellulose, the precursors for lipid and amino acid biosynthesis, or as a fuel in cellular respiration. The latter occurs not only in plants but also in animals when the energy from plants is passed through a food chain.

The fixation or reduction of carbon dioxide is a process in which carbon dioxide combines with a five-carbon sugar, ribulose 1,5-bisphosphate, to yield two molecules of a three-carbon compound, glycerate 3-phosphate, also known as 3-phosphoglycerate. Glycerate 3-phosphate, in the presence of ATP and NADPH produced during the light-dependent

stages, is reduced to glyceraldehyde 3-phosphate. This product is also referred to as 3-phosphoglyceraldehyde (PGAL) or, more generically, as triose phosphate. Most (5 out of 6 molecules) of the glyceraldehyde 3-phosphate produced is used to regenerate ribulose 1,5-bisphosphate so the process can continue. The triose phosphates not thus "recycled" often condense to form hexose phosphates, which ultimately yield sucrose, starch and cellulose. The sugars produced during carbon metabolism yield carbon skeletons that can be used for other metabolic reactions like the production of amino acids and lipids.

# Carbon concentrating mechanisms

## On land

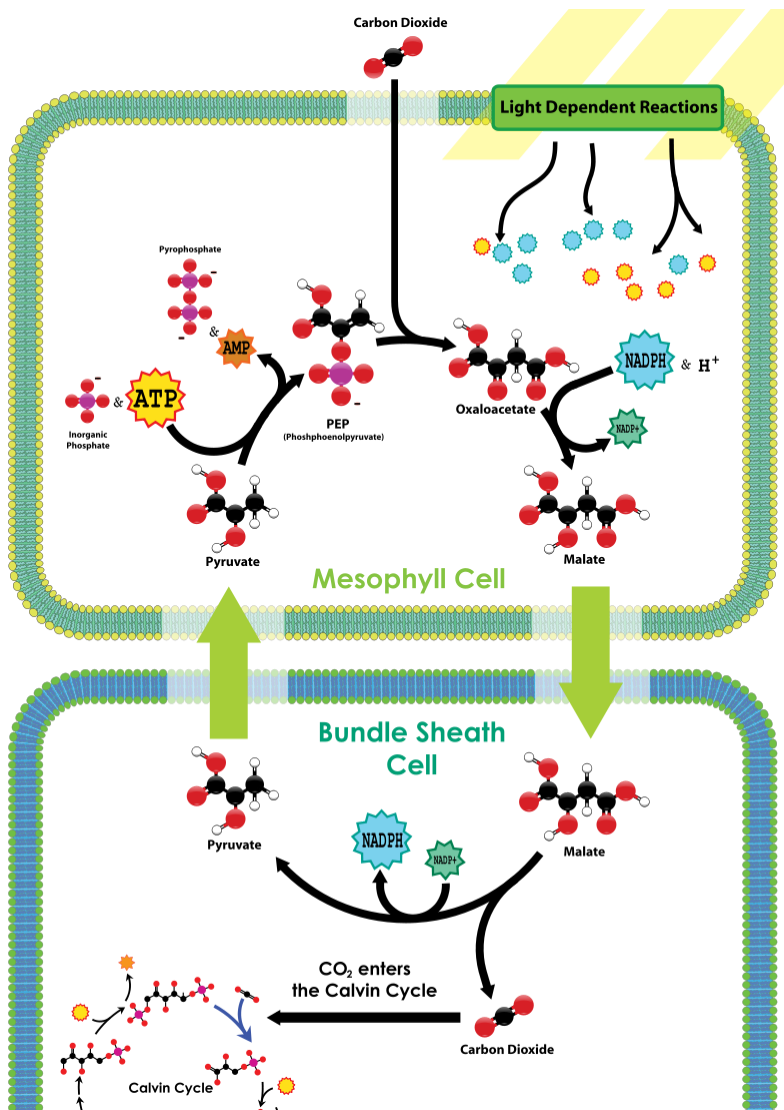

Overview of C4 carbon fixation

In hot and dry conditions, plants close their stomata to prevent water loss. Under these conditions,  $\text{CO}_2$  will decrease and oxygen gas, produced by the light reactions of photosynthesis, will increase, causing an increase of photorespiration by the oxygenase activity of ribulose-1,5-bisphosphate carboxylase/oxygenase and decrease in carbon fixation. Some plants have evolved mechanisms to increase the  $\text{CO}_2$  concentration in the leaves under these conditions. [28]

Plants that use the C<sub>4</sub> carbon fixation process chemically fix carbon dioxide in the cells of the mesophyll by adding it to

the three-carbon molecule phosphoenolpyruvate (PEP), a reaction catalyzed by an enzyme called PEP carboxylase, creating the four-carbon organic acid oxaloacetic acid. Oxaloacetic acid or malate synthesized by this process is then translocated to specialized bundle sheath cells where the enzyme RuBisCO and other Calvin cycle enzymes are located, and where  $\text{CO}_2$  released by decarboxylation of the four-carbon acids is then fixed by RuBisCO activity to the three-carbon 3-phosphoglyceric acids. The physical separation of RuBisCO from the oxygen-generating light reactions reduces photorespiration and increases  $\text{CO}_2$

fixation and, thus, the photosynthetic capacity of the leaf.<sup>[29]</sup> C<sub>4</sub> plants can produce more sugar than C<sub>3</sub> plants in conditions of high light and temperature. Many important crop plants are C<sub>4</sub> plants, including maize, sorghum, sugarcane, and millet. Plants that do not use PEP-carboxylase in carbon fixation are called C<sub>3</sub> plants because the primary carboxylation reaction, catalyzed by RuBisCO, produces the three-carbon 3-phosphoglyceric acids directly in the Calvin-Benson cycle. Over 90% of plants use C<sub>3</sub> carbon fixation, compared to 3% that use C<sub>4</sub> carbon fixation;<sup>[30]</sup> however, the evolution of C<sub>4</sub> in over 60 plant



lineages makes it a striking example of convergent evolution.<sup>[28]</sup>

Xerophytes, such as cacti and most succulents, also use PEP carboxylase to capture carbon dioxide in a process called Crassulacean acid metabolism (CAM). In contrast to C<sub>4</sub> metabolism, which *spatially* separates the CO<sub>2</sub> fixation to PEP from the Calvin cycle, CAM *temporally* separates these two processes. CAM plants have a different leaf anatomy from C<sub>3</sub> plants, and fix the CO<sub>2</sub> at night, when their stomata are open. CAM plants store the CO<sub>2</sub> mostly in the form of malic acid via carboxylation of phosphoenolpyruvate to oxaloacetate,

which is then reduced to malate.

Decarboxylation of malate during the day releases  $\text{CO}_2$  inside the leaves, thus allowing carbon fixation to 3-phosphoglycerate by RuBisCO. Sixteen thousand species of plants use CAM.<sup>[31]</sup>

## **In water**

Cyanobacteria possess carboxysomes, which increase the concentration of  $\text{CO}_2$  around RuBisCO to increase the rate of photosynthesis. An enzyme, carbonic anhydrase, located within the carboxysome releases  $\text{CO}_2$  from the dissolved hydrocarbonate ions ( $\text{HCO}_3^-$ ).

Before the  $\text{CO}_2$  diffuses out it is quickly sponged up by RuBisCO, which is concentrated within the carboxysomes.

$\text{HCO}_3^-$  ions are made from  $\text{CO}_2$  outside the cell by another carbonic anhydrase and are actively pumped into the cell by a membrane protein. They cannot cross the membrane as they are charged, and within the cytosol they turn back into  $\text{CO}_2$  very slowly without the help of carbonic anhydrase. This causes the  $\text{HCO}_3^-$  ions to accumulate within the cell from where they diffuse into the carboxysomes. [32]

Pyrenoids in algae and hornworts also act to concentrate  $\text{CO}_2$  around RuBisCO. [33]

# Order and kinetics

---

The overall process of photosynthesis takes place in four stages:<sup>[13]</sup>

Stage	Description	Time scale
1	Energy transfer in antenna chlorophyll (thylakoid membranes)	<u>femtosecond</u> to <u>picosecond</u>
2	Transfer of electrons in photochemical reactions (thylakoid membranes)	<u>picosecond</u> to <u>nanosecond</u>
3	Electron transport chain and ATP synthesis (thylakoid membranes)	<u>microsecond</u> to <u>millisecond</u>
4	Carbon fixation and export of stable products	<u>millisecond</u> to <u>second</u>

## Efficiency

---

Plants usually convert light into chemical energy with a photosynthetic efficiency of 3–6%.<sup>[34]</sup> Absorbed light that is unconverted is dissipated primarily as heat, with a small fraction (1–2%)<sup>[35]</sup> re-

emitted as chlorophyll fluorescence at longer (redder) wavelengths. This fact allows measurement of the light reaction of photosynthesis by using chlorophyll fluorometers.<sup>[35]</sup>

Actual plants' photosynthetic efficiency varies with the frequency of the light being converted, light intensity, temperature and proportion of carbon dioxide in the atmosphere, and can vary from 0.1% to 8%.<sup>[36]</sup> By comparison, solar panels convert light into electric energy at an efficiency of approximately 6–20% for mass-produced panels, and above 40% in laboratory devices.

The efficiency of both light and dark reactions can be measured but the relationship between the two can be complex.<sup>[37]</sup> For example, the ATP and NADPH energy molecules, created by the light reaction, can be used for carbon fixation or for photorespiration in C<sub>3</sub> plants.<sup>[37]</sup> Electrons may also flow to other electron sinks.<sup>[38][39][40]</sup> For this reason, it is not uncommon for authors to differentiate between work done under non-photorespiratory conditions and under photorespiratory conditions.<sup>[41][42][43]</sup>

Chlorophyll fluorescence of photosystem II can measure the light reaction, and

Infrared gas analyzers can measure the dark reaction.<sup>[44]</sup> It is also possible to investigate both at the same time using an integrated chlorophyll fluorometer and gas exchange system, or by using two separate systems together.<sup>[45]</sup> Infrared gas analyzers and some moisture sensors are sensitive enough to measure the photosynthetic assimilation of CO<sub>2</sub>, and of ΔH<sub>2</sub>O using reliable methods.<sup>[46]</sup> CO<sub>2</sub> is commonly measured in μmols/(m<sup>2</sup>/s), parts per million or volume per million and H<sub>2</sub>O is commonly measured in mmol/(m<sup>2</sup>/s) or in mbars.<sup>[46]</sup> By measuring CO<sub>2</sub> assimilation, ΔH<sub>2</sub>O, leaf temperature, barometric pressure, leaf area, and

photosynthetically active radiation or PAR, it becomes possible to estimate, "A" or carbon assimilation, "E" or transpiration, "gs" or stomatal conductance, and  $C_i$  or intracellular  $CO_2$ .<sup>[46]</sup> However, it is more common to use chlorophyll fluorescence for plant stress measurement, where appropriate, because the most commonly used measuring parameters FV/FM and Y(II) or F/FM' can be made in a few seconds, allowing the measurement of larger plant populations.<sup>[43]</sup>

Gas exchange systems that offer control of  $CO_2$  levels, above and below ambient, allow the common practice of



measurement of A/Ci curves, at different CO<sub>2</sub> levels, to characterize a plant's photosynthetic response.<sup>[46]</sup>

Integrated chlorophyll fluorometer – gas exchange systems allow a more precise measure of photosynthetic response and mechanisms.<sup>[44][45]</sup> While standard gas exchange photosynthesis systems can measure Ci, or substomatal CO<sub>2</sub> levels, the addition of integrated chlorophyll fluorescence measurements allows a more precise measurement of C<sub>C</sub> to replace Ci.<sup>[45][47]</sup> The estimation of CO<sub>2</sub> at the site of carboxylation in the chloroplast, or C<sub>C</sub>, becomes possible with the

measurement of mesophyll conductance or  $g_m$  using an integrated system.<sup>[44][45][48]</sup>

Photosynthesis measurement systems are not designed to directly measure the amount of light absorbed by the leaf. But analysis of chlorophyll-fluorescence, P700- and P515-absorbance and gas exchange measurements reveal detailed information about e.g. the photosystems, quantum efficiency and the  $CO_2$  assimilation rates. With some instruments even wavelength-dependency of the photosynthetic efficiency can be analyzed.<sup>[49]</sup>

A phenomenon known as quantum walk increases the efficiency of the energy transport of light significantly. In the photosynthetic cell of an algae, bacterium, or plant, there are light-sensitive molecules called chromophores arranged in an antenna-shaped structure named a photocomplex. When a photon is absorbed by a chromophore, it is converted into a quasiparticle referred to as an exciton, which jumps from chromophore to chromophore towards the reaction center of the photocomplex, a collection of molecules that traps its energy in a chemical form that makes it accessible for the cell's metabolism. The

exciton's wave properties enable it to cover a wider area and try out several possible paths simultaneously, allowing it to instantaneously "choose" the most efficient route, where it will have the highest probability of arriving at its destination in the minimum possible time. Because that quantum walking takes place at temperatures far higher than quantum phenomena usually occur, it is only possible over very short distances, due to obstacles in the form of destructive interference that come into play. These obstacles cause the particle to lose its wave properties for an instant before it regains them once again after it is freed

from its locked position through a classic "hop". The movement of the electron towards the photo center is therefore covered in a series of conventional hops and quantum walks. <sup>[50][51][52]</sup>

# Evolution

## Life timeline

This box: [view](#) [talk](#) [edit](#)

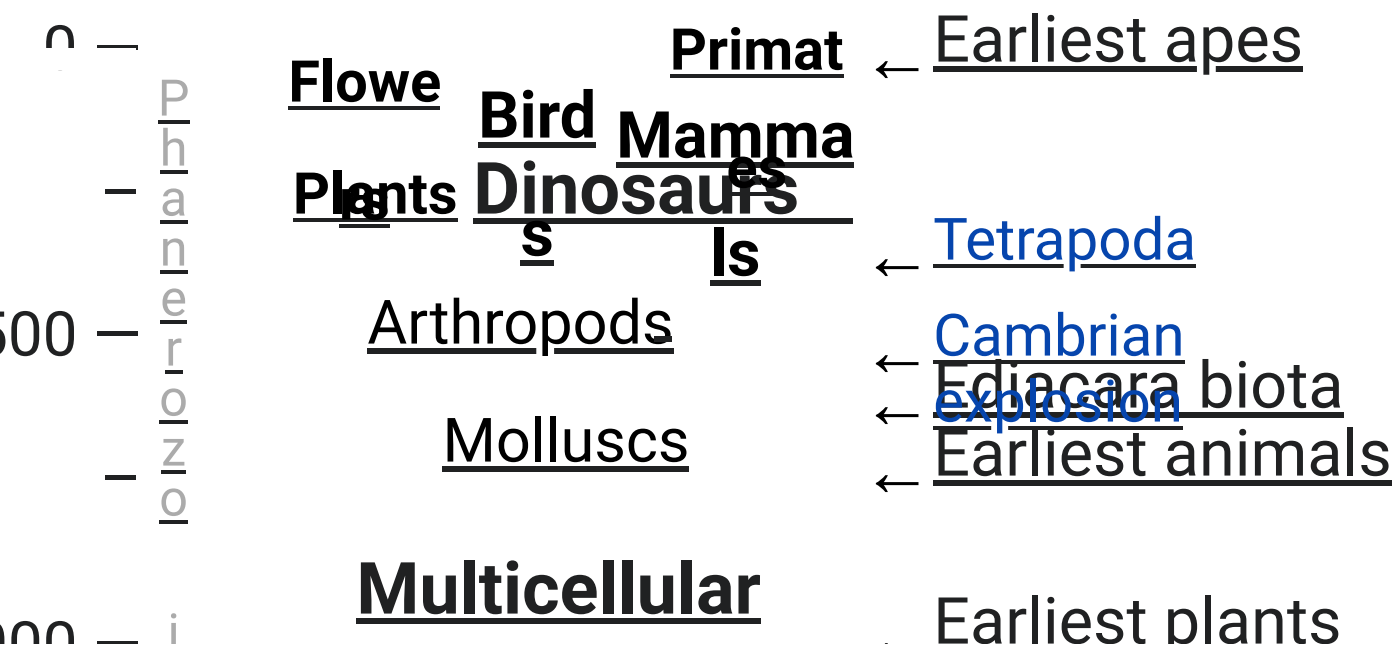

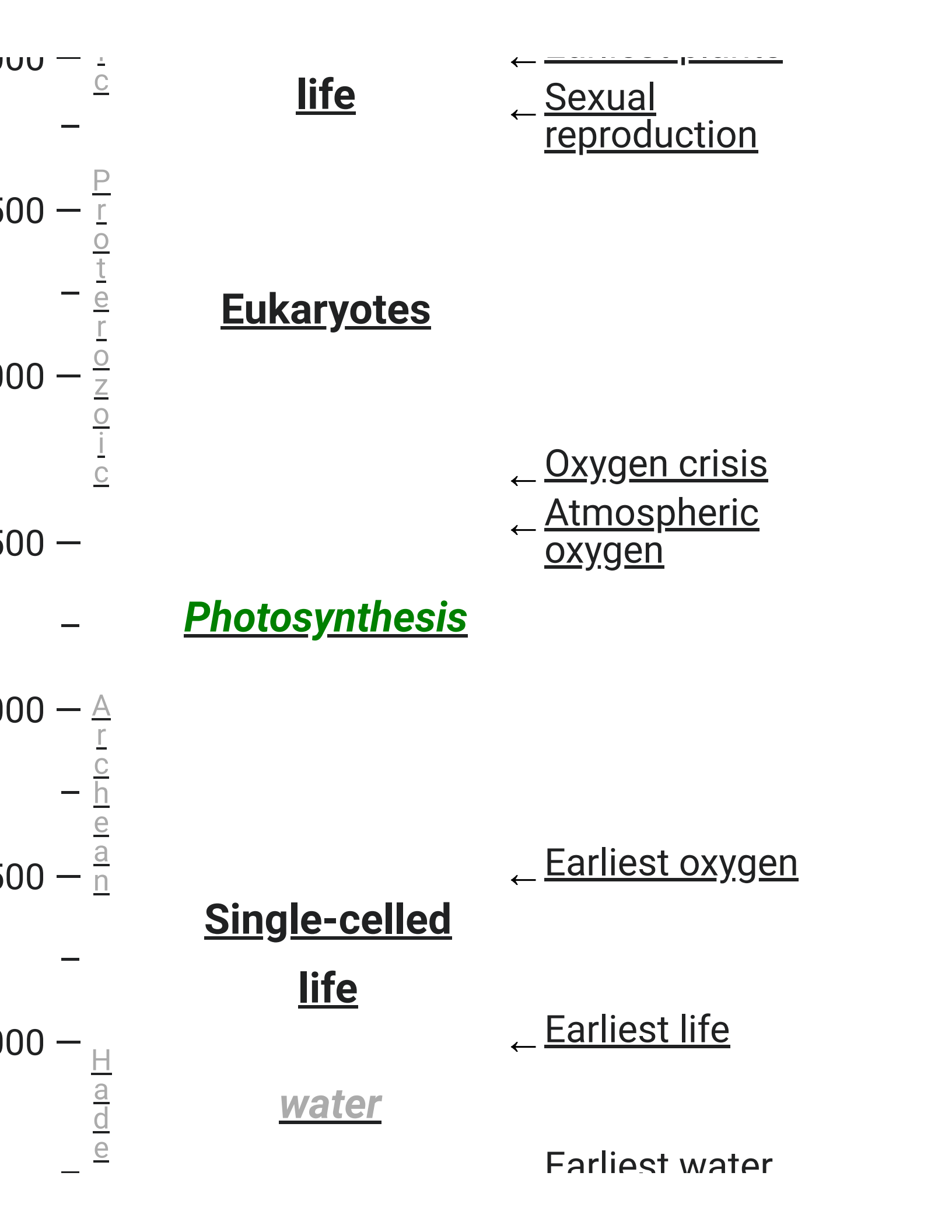

life

← Sexual reproduction

Eukaryotes

← Oxygen crisis  
← Atmospheric oxygen

Photosynthesis

← Earliest oxygen

Single-celled life

← Earliest life

water

Earliest water

500 –  $\frac{a}{n}$   
million years ago)

← Earliest water  
← Earth (-4540)  
Clickable



Early photosynthetic systems, such as those in green and purple sulfur and green and purple nonsulfur bacteria, are thought to have been anoxygenic, and used various other molecules than water as electron donors. Green and purple sulfur bacteria are thought to have used hydrogen and sulfur as electron donors. Green nonsulfur bacteria used various amino and other organic acids as an electron donor. Purple nonsulfur bacteria used a variety of nonspecific organic molecules. The use of these molecules is consistent with the

geological evidence that Earth's early atmosphere was highly reducing at that time.<sup>[53]</sup>

Fossils of what are thought to be filamentous photosynthetic organisms have been dated at 3.4 billion years old.<sup>[54][55]</sup> More recent studies, reported in March 2018, also suggest that photosynthesis may have begun about 3.4 billion years ago.<sup>[56][57]</sup>

The main source of oxygen in the Earth's atmosphere derives from oxygenic photosynthesis, and its first appearance is sometimes referred to as the oxygen



catastrophe. Geological evidence suggests that oxygenic photosynthesis, such as that in cyanobacteria, became important during the Paleoproterozoic era around 2 billion years ago. Modern photosynthesis in plants and most photosynthetic prokaryotes is oxygenic. Oxygenic photosynthesis uses water as an electron donor, which is oxidized to molecular oxygen ( $O_2$ ) in the photosynthetic reaction center.

## **Symbiosis and the origin of chloroplasts**

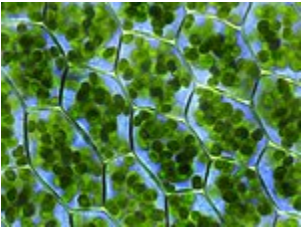

*Plant cells with visible chloroplasts (from a moss, Plagiomnium affine)*

Several groups of animals have formed symbiotic relationships with photosynthetic algae. These are most common in corals, sponges and sea anemones. It is presumed that this is due to the particularly simple body plans and large surface areas of these animals compared to their volumes.<sup>[58]</sup> In addition, a few marine mollusks *Elysia viridis* and *Elysia chlorotica* also maintain a symbiotic

relationship with chloroplasts they capture from the algae in their diet and then store in their bodies (see Kleptoplasty). This allows the mollusks to survive solely by photosynthesis for several months at a time.<sup>[59][60]</sup> Some of the genes from the plant cell nucleus have even been transferred to the slugs, so that the chloroplasts can be supplied with proteins that they need to survive.<sup>[61]</sup>

An even closer form of symbiosis may explain the origin of chloroplasts.

Chloroplasts have many similarities with photosynthetic bacteria, including a circular chromosome, prokaryotic-type

ribosome, and similar proteins in the photosynthetic reaction center.<sup>[62][63]</sup> The endosymbiotic theory suggests that photosynthetic bacteria were acquired (by endocytosis) by early eukaryotic cells to form the first plant cells. Therefore, chloroplasts may be photosynthetic bacteria that adapted to life inside plant cells. Like mitochondria, chloroplasts possess their own DNA, separate from the nuclear DNA of their plant host cells and the genes in this chloroplast DNA resemble those found in cyanobacteria.<sup>[64]</sup> DNA in chloroplasts codes for redox proteins such as those found in the photosynthetic reaction centers. The CoRR

Hypothesis proposes that this co-location of genes with their gene products is required for redox regulation of gene expression, and accounts for the persistence of DNA in bioenergetic organelles.<sup>[65]</sup>

## **Photosynthetic eukaryotic lineages**

Symbiotic and kleptoplastic organisms excluded:

- The glaucophytes and the red and green algae—clade Archaeplastida (unicellular and multicellular)

- The cryptophytes—clade Cryptista (unicellular)
- The haptophytes—clade Haptista (unicellular)
- The dinoflagellates and chromerids in the superphylum Myzozoa—clade Alveolata (unicellular)
- The ochrophytes—clade Heterokonta (unicellular and multicellular)
- The chlorarachniophytes and three species of Paulinella in the phylum Cercozoa—clade Rhizaria (unicellular)
- The euglenids—clade Excavata (unicellular)

Except for the euglenids, all of them belongs to the Diaphoretickes.

Archaeplastida and the photosynthetic Paulinella got their plastids through primary endosymbiosis in two separate events by engulfing a cyanobacterium. The plastids in all the other groups have either a red or green algal origin, and are referred to as the "red lineages" and the "green lineages". While able to perform photosynthesis, many of them are mixotrophs and practice heterotrophy to various degrees.

## **Cyanobacteria and the evolution of photosynthesis**

The biochemical capacity to use water as the source for electrons in photosynthesis evolved once, in a common ancestor of extant cyanobacteria (formerly called blue-green algae), which are the only prokaryotes performing oxygenic photosynthesis. The geological record indicates that this transforming event took place early in Earth's history, at least 2450–2320 million years ago (Ma), and, it is speculated, much earlier.<sup>[66][67]</sup> Because the Earth's atmosphere contained almost no oxygen during the estimated development of photosynthesis, it is believed that the first photosynthetic



cyanobacteria did not generate oxygen.<sup>[68]</sup> Available evidence from geobiological studies of Archean (>2500 Ma) sedimentary rocks indicates that life existed 3500 Ma, but the question of when oxygenic photosynthesis evolved is still unanswered. A clear paleontological window on cyanobacterial evolution opened about 2000 Ma, revealing an already-diverse biota of Cyanobacteria. Cyanobacteria remained the principal primary producers of oxygen throughout the Proterozoic Eon (2500–543 Ma), in part because the redox structure of the oceans favored photoautotrophs capable of nitrogen fixation. Green algae joined

cyanobacteria as the major primary producers of oxygen on continental shelves near the end of the Proterozoic, but it was only with the Mesozoic (251–66 Ma) radiations of dinoflagellates, coccolithophorids, and diatoms did the primary production of oxygen in marine shelf waters take modern form.

Cyanobacteria remain critical to marine ecosystems as primary producers of oxygen in oceanic gyres, as agents of biological nitrogen fixation, and, in modified form, as the plastids of marine algae.<sup>[69]</sup>

## Discovery

Although some of the steps in photosynthesis are still not completely understood, the overall photosynthetic equation has been known since the 19th century.



*Portrait of Jan Baptist van Helmont by Mary Beale,  
c.1674*

Jan van Helmont began the research of the process in the mid-17th century when he carefully measured the mass of the soil used by a plant and the mass of the plant as it grew. After noticing that the soil mass changed very little, he hypothesized that the mass of the growing plant must come from the water, the only substance he added to the potted plant. His hypothesis was partially accurate – much of the gained mass also comes from carbon dioxide as well as water. However, this was a signaling point to the idea that the bulk of a plant's biomass comes from the inputs of photosynthesis, not the soil itself.

Joseph Priestley, a chemist and minister, discovered that, when he isolated a volume of air under an inverted jar, and burned a candle in it (which gave off  $\text{CO}_2$ ), the candle would burn out very quickly, much before it ran out of wax. He further discovered that a mouse could similarly "injure" air. He then showed that the air that had been "injured" by the candle and the mouse could be restored by a plant.

In 1778, Jan Ingenhousz, repeated Priestley's experiments. He discovered that it was the influence of sunlight on the plant that could cause it to revive a mouse in a matter of hours.

In 1796, Jean Senebier, a Swiss pastor, botanist, and naturalist, demonstrated that green plants consume carbon dioxide and release oxygen under the influence of light. Soon afterward, Nicolas-Théodore de Saussure showed that the increase in mass of the plant as it grows could not be due only to uptake of  $\text{CO}_2$  but also to the incorporation of water. Thus, the basic reaction by which photosynthesis is used to produce food (such as glucose) was outlined.<sup>[70]</sup>

Cornelis Van Niel made key discoveries explaining the chemistry of photosynthesis. By studying purple sulfur

bacteria and green bacteria he was the first to demonstrate that photosynthesis is a light-dependent redox reaction, in which hydrogen reduces (donates its  $e^-$  electron to) carbon dioxide.

Robert Emerson discovered two light reactions by testing plant productivity using different wavelengths of light. With the red alone, the light reactions were suppressed. When blue and red were combined, the output was much more substantial. Thus, there were two photosystems, one absorbing up to 600 nm wavelengths, the other up to 700 nm. The former is known as PSII, the

latter is PSI. PSI contains only chlorophyll "a", PSII contains primarily chlorophyll "a" with most of the available chlorophyll "b", among other pigment. These include phycobilins, which are the red and blue pigments of red and blue algae respectively, and fucoxanthol for brown algae and diatoms. The process is most productive when the absorption of quanta are equal in both the PSII and PSI, assuring that input energy from the antenna complex is divided between the PSI and PSII system, which in turn powers the photochemistry.<sup>[13]</sup>



Robert Hill thought that a complex of reactions consisting of an intermediate to cytochrome  $b_6$  (now a plastoquinone), another is from cytochrome f to a step in the carbohydrate-generating mechanisms. These are linked by plastoquinone, which does require energy to reduce cytochrome f for it is a sufficient reductant. Further experiments to prove that the oxygen developed during the photosynthesis of green plants came from water, were performed by Hill in 1937 and 1939. He showed that isolated chloroplasts give off oxygen in the presence of unnatural reducing agents like iron oxalate, ferricyanide or benzoquinone after

exposure to light. The Hill reaction<sup>[71]</sup> is as follows:

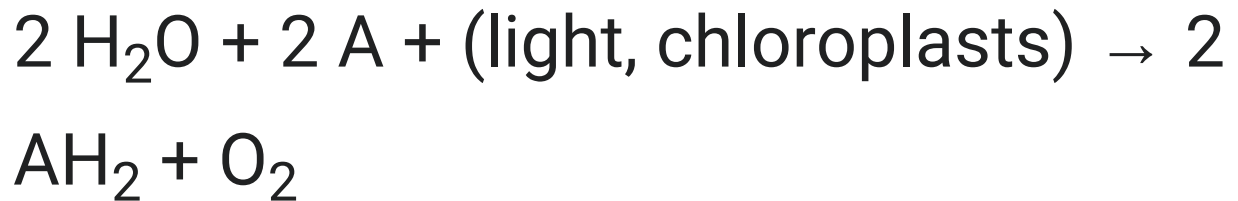

where A is the electron acceptor.

Therefore, in light, the electron acceptor is reduced and oxygen is evolved.

Samuel Ruben and Martin Kamen used radioactive isotopes to determine that the oxygen liberated in photosynthesis came from the water.



*Melvin Calvin works in his photosynthesis laboratory.*

Melvin Calvin and Andrew Benson, along with James Bassham, elucidated the path of carbon assimilation (the photosynthetic carbon reduction cycle) in plants. The carbon reduction cycle is known as the Calvin cycle, which ignores the contribution of Bassham and Benson. Many scientists refer to the cycle as the Calvin-Benson Cycle, Benson-Calvin, and

some even call it the Calvin-Benson-Bassham (or CBB) Cycle.

Nobel Prize-winning scientist Rudolph A. Marcus was able to discover the function and significance of the electron transport chain.

Otto Heinrich Warburg and Dean Burk discovered the I-quantum photosynthesis reaction that splits the  $\text{CO}_2$ , activated by the respiration.<sup>[72]</sup>

In 1950, first experimental evidence for the existence of photophosphorylation *in vivo* was presented by Otto Kandler using intact Chlorella cells and interpreting his

findings as light-dependent ATP formation.<sup>[73]</sup> In 1954, Daniel I. Arnon et al. discovered photophosphorylation *in vitro* in isolated chloroplasts with the help of  $P^{32}$ .<sup>[74][75]</sup>

Louis N.M. Duysens and Jan Amesz

discovered that chlorophyll a will absorb one light, oxidize cytochrome f, chlorophyll a (and other pigments) will absorb another light, but will reduce this same oxidized cytochrome, stating the two light reactions are in series.

## **Development of the concept**

In 1893, Charles Reid Barnes proposed two terms, *photosyntax* and *photosynthesis*, for the biological process of *synthesis of complex carbon compounds out of carbonic acid, in the presence of chlorophyll, under the influence of light*. Over time, the term *photosynthesis* came into common usage as the term of choice. Later discovery of anoxygenic photosynthetic bacteria and photophosphorylation necessitated redefinition of the term.<sup>[76]</sup>

## **C3 : C4 photosynthesis research**

After WWII at late 1940 at the University of California, Berkeley, the details of photosynthetic carbon metabolism were sorted out by the chemists Melvin Calvin, Andrew Benson, James Bassham and a score of students and researchers utilizing the carbon-14 isotope and paper chromatography techniques.<sup>[77]</sup> The pathway of CO<sub>2</sub> fixation by the algae *Chlorella* in a fraction of a second in light resulted in a 3 carbon molecule called phosphoglyceric acid (PGA). For that original and ground-breaking work, a Nobel Prize in Chemistry was awarded to Melvin Calvin in 1961. In parallel, plant physiologists studied leaf gas exchanges

using the new method of infrared gas analysis and a leaf chamber where the net photosynthetic rates ranged from 10 to 13  $\mu\text{mol CO}_2 \cdot \text{m}^{-2} \cdot \text{s}^{-1}$ , with the conclusion that all terrestrial plants having the same photosynthetic capacities that were light saturated at less than 50% of sunlight. <sup>[78][79]</sup>

Later in 1958–1963 at Cornell University, field grown maize was reported to have much greater leaf photosynthetic rates of 40  $\mu\text{mol CO}_2 \cdot \text{m}^{-2} \cdot \text{s}^{-1}$  and was not saturated at near full sunlight. <sup>[80][81]</sup> This higher rate in maize was almost double those observed in other species such as



wheat and soybean, indicating that large differences in photosynthesis exist among higher plants. At the University of Arizona, detailed gas exchange research on more than 15 species of monocot and dicot uncovered for the first time that differences in leaf anatomy are crucial factors in differentiating photosynthetic capacities among species.<sup>[82][83]</sup> In tropical grasses, including maize, sorghum, sugarcane, Bermuda grass and in the dicot amaranthus, leaf photosynthetic rates were around  $38\text{--}40 \mu\text{mol CO}_2 \cdot \text{m}^{-2} \cdot \text{s}^{-1}$ , and the leaves have two types of green cells, i. e. outer layer of mesophyll cells surrounding a tightly packed

chlorophyllous vascular bundle sheath cells. This type of anatomy was termed Kranz anatomy in the 19th century by the botanist Gottlieb Haberlandt while studying leaf anatomy of sugarcane.<sup>[84]</sup> Plant species with the greatest photosynthetic rates and Kranz anatomy showed no apparent photorespiration, very low CO<sub>2</sub> compensation point, high optimum temperature, high stomatal resistances and lower mesophyll resistances for gas diffusion and rates never saturated at full sun light.<sup>[85]</sup> The research at Arizona was designated Citation Classic by the ISI 1986.<sup>[83]</sup> These species was later termed C4 plants as the

first stable compound of CO<sub>2</sub> fixation in light has 4 carbon as malate and aspartate.<sup>[86][87][88]</sup> Other species that lack Kranz anatomy were termed C3 type such as cotton and sunflower, as the first stable carbon compound is the 3-carbon PGA. At 1000 ppm CO<sub>2</sub> in measuring air, both the C3 and C4 plants had similar leaf photosynthetic rates around 60 μmol CO<sub>2</sub>·m<sup>-2</sup>·s<sup>-1</sup> indicating the suppression of photorespiration in C3 plants.<sup>[82][83]</sup>

## Factors



*The leaf is the primary site of photosynthesis in plants.*

There are three main factors affecting photosynthesis and several corollary factors. The three main are:

- Light irradiance and wavelength
- Carbon dioxide concentration
- Temperature.

Total photosynthesis is limited by a range of environmental factors. These include the amount of light available, the amount

of leaf area a plant has to capture light (shading by other plants is a major limitation of photosynthesis), rate at which carbon dioxide can be supplied to the chloroplasts to support photosynthesis, the availability of water, and the availability of suitable temperatures for carrying out photosynthesis.<sup>[89]</sup>

**Light intensity (irradiance),  
wavelength and temperature**

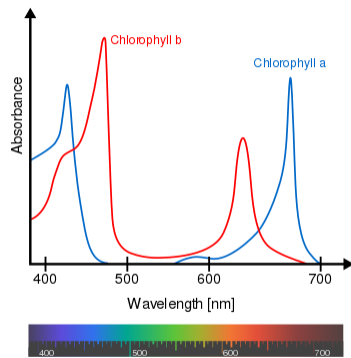

Absorbance spectra of free chlorophyll a (*blue*) and b (*red*) in a solvent. The action spectra of chlorophyll molecules are slightly modified *in vivo* depending on specific pigment–protein interactions.

The process of photosynthesis provides the main input of free energy into the biosphere, and is one of four main ways in which radiation is important for plant life.<sup>[90]</sup>

The radiation climate within plant communities is extremely variable, with

both time and space.

In the early 20th century, Frederick

Blackman and Gabrielle Matthaei

investigated the effects of light intensity (irradiance) and temperature on the rate of carbon assimilation.

- At constant temperature, the rate of carbon assimilation varies with irradiance, increasing as the irradiance increases, but reaching a plateau at higher irradiance.
- At low irradiance, increasing the temperature has little influence on the rate of carbon assimilation. At constant

high irradiance, the rate of carbon assimilation increases as the temperature is increased.

These two experiments illustrate several important points: First, it is known that, in general, photochemical reactions are not affected by temperature. However, these experiments clearly show that temperature affects the rate of carbon assimilation, so there must be two sets of reactions in the full process of carbon assimilation. These are the light-dependent 'photochemical' temperature-independent stage, and the light-independent, temperature-dependent stage. Second, Blackman's experiments



illustrate the concept of limiting factors. Another limiting factor is the wavelength of light. Cyanobacteria, which reside several meters underwater, cannot receive the correct wavelengths required to cause photoinduced charge separation in conventional photosynthetic pigments. To combat this problem, a series of proteins with different pigments surround the reaction center. This unit is called a phycobilisome.

## **Carbon dioxide levels and photorespiration**

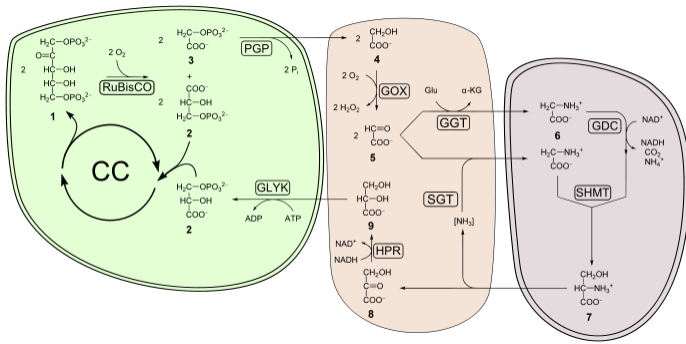

## Photorespiration

As carbon dioxide concentrations rise, the rate at which sugars are made by the light-independent reactions increases until limited by other factors. RuBisCO, the enzyme that captures carbon dioxide in the light-independent reactions, has a binding affinity for both carbon dioxide and oxygen. When the concentration of carbon dioxide is high, RuBisCO will fix carbon dioxide. However, if the carbon dioxide

concentration is low, RuBisCO will bind oxygen instead of carbon dioxide. This process, called photorespiration, uses energy, but does not produce sugars.

RuBisCO oxygenase activity is disadvantageous to plants for several reasons:

1. One product of oxygenase activity is phosphoglycolate (2 carbon) instead of 3-phosphoglycerate (3 carbon). Phosphoglycolate cannot be metabolized by the Calvin-Benson cycle and represents carbon lost from the cycle. A high oxygenase

activity, therefore, drains the sugars that are required to recycle ribulose 5-bisphosphate and for the continuation of the Calvin-Benson cycle.

2. Phosphoglycolate is quickly metabolized to glycolate that is toxic to a plant at a high concentration; it inhibits photosynthesis.
3. Salvaging glycolate is an energetically expensive process that uses the glycolate pathway, and only 75% of the carbon is returned to the Calvin-Benson cycle as 3-phosphoglycerate. The reactions also

produce ammonia (NH<sub>3</sub>), which is able to diffuse out of the plant, leading to a loss of nitrogen.

A highly simplified summary is:

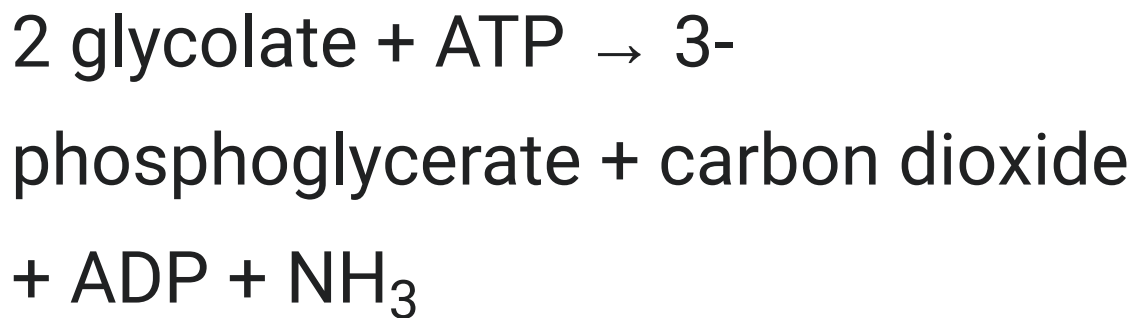

The salvaging pathway for the products of RuBisCO oxygenase activity is more commonly known as photorespiration, since it is characterized by light-dependent oxygen consumption and the release of carbon dioxide.

See also

- Jan Anderson (scientist).
- Artificial photosynthesis
- Calvin-Benson cycle
- Carbon fixation
- Cellular respiration
- Chemosynthesis
- Daily light integral
- Hill reaction
- Integrated fluorometer
- Light-dependent reaction
- Organic reaction
- Photobiology.
- Photoinhibition
- Photosynthetic reaction center

- Photosynthetically active radiation
- Photosystem
- Photosystem I
- Photosystem II
- Quantum biology.
- Radiosynthesis
- Red edge
- Vitamin D

## References

---

1. *"photosynthesis" . Online Etymology Dictionary. Archived from the original on 2013-03-07. Retrieved 2013-05-23.*

2. φῶς . *Liddell, Henry George; Scott, Robert; A Greek–English Lexicon at the Perseus Project*
3. σύνθεσις . *Liddell, Henry George; Scott, Robert; A Greek–English Lexicon at the Perseus Project*
4. *Bryant DA, Frigaard NU (Nov 2006). "Prokaryotic photosynthesis and phototrophy illuminated". Trends in Microbiology. 14 (11): 488–496. doi:10.1016/j.tim.2006.09.001 . PMID 16997562 .*



5. Reece J, Urry L, Cain M, Wasserman S, Minorsky P, Jackson R (2011). *Biology (International ed.)*. Upper Saddle River, NJ: Pearson Education. pp. 235, 244 . ISBN 978-0-321-73975-9. "This initial incorporation of carbon into organic compounds is known as carbon fixation."

6. Olson JM (May 2006). "Photosynthesis in the Archean era". *Photosynthesis Research*. **88** (2): 109–117. doi:10.1007/s11120-006-9040-5 . PMID 16453059 .

7. Buick R (Aug 2008). "When did oxygenic photosynthesis evolve?" . *Philosophical Transactions of the Royal Society of London, Series B.* **363** (1504): 2731–2743.  
doi:10.1098/rstb.2008.0041 .  
PMC 2606769 . PMID 18468984 .
8. Nealson KH, Conrad PG (Dec 1999). "Life: past, present and future" . *Philosophical Transactions of the Royal Society of London, Series B.* **354** (1392): 1923–1939.  
doi:10.1098/rstb.1999.0532 .  
PMC 1692713 . PMID 10670014 .

9. *Whitmarsh J, Govindjee (1999). "The photosynthetic process" . In Singhal GS, Renger G, Sopory SK, Irrgang KD, Govindjee (eds.). Concepts in photobiology: photosynthesis and photomorphogenesis. Boston: Kluwer Academic Publishers. pp. 11–51. ISBN 978-0-7923-5519-9. "100 × 10<sup>15</sup> grams of carbon/year fixed by photosynthetic organisms, which is equivalent to 4 × 10<sup>18</sup> kJ/yr = 4 × 10<sup>21</sup> J/yr of free energy stored as reduced carbon."*

10. *Steger U, Achterberg W, Blok K, Bode H, Frenz W, Gather C, Hanekamp G, Imboden D, Jahnke M, Kost M, Kurz R, Nutzinger HG, Zieseimer T (2005). Sustainable development and innovation in the energy sector . Berlin: Springer. p. 32. ISBN 978-3-540-23103-5. Archived from the original on 2016-09-02. Retrieved 2016-02-21. "The average global rate of photosynthesis is 130 TW."*

11. *"World Consumption of Primary Energy by Energy Type and Selected Country Groups, 1980–2004" . Energy Information Administration. July 31, 2006. Archived from the original (XLS) on November 9, 2006. Retrieved 2007-01-20.*

12. *Field CB, Behrenfeld MJ, Randerson JT, Falkowski P (Jul 1998). "Primary production of the biosphere: integrating terrestrial and oceanic components" . Science. **281** (5374): 237–240.*

*Bibcode:1998Sci...281..237F .*

*doi:10.1126/science.281.5374.237 .*

*PMID 9657713 . Archived from the original on 2018-09-25. Retrieved 2018-04-20.*

13. *"Photosynthesis". McGraw-Hill Encyclopedia of Science & Technology. **13**. New York: McGraw-Hill. 2007. ISBN 978-0-07-144143-8.*

14. *Whitmarsh J, Govindjee (1999). "Chapter 2: The Basic Photosynthetic Process" . In Singhal GS, Renger G, Sopory SK, Irrgang KD, Govindjee (eds.). Concepts in Photobiology: Photosynthesis and Photomorphogenesis. Boston: Kluwer Academic Publishers. p. 13. ISBN 978-0-7923-5519-9.*
15. *Anaerobic Photosynthesis, Chemical & Engineering News, **86**, 33, August 18, 2008, p. 36*

16. *Kulp TR, Hoeft SE, Asao M, Madigan MT, Hollibaugh JT, Fisher JC, Stolz JF, Culbertson CW, Miller LG, Oremland RS (Aug 2008). "Arsenic(III) fuels anoxygenic photosynthesis in hot spring biofilms from Mono Lake, California" . Science. 321 (5891): 967–970. Bibcode:2008Sci...321..967K . doi:10.1126/science.1160799 . PMID 18703741 .*
17. *"Scientists discover unique microbe in California's largest lake" . Archived from the original on 2009-07-12. Retrieved 2009-07-20.*



18. *Plants: Diversity and Evolution*

*Archived 2016-09-01 at the Wayback Machine, page 14, Martin Ingrouille, Bill Eddie*

19. *Oakley T (19 December 2008).*

*"Evolutionary Novelties: Opsins: An amazing evolutionary convergence" .*

*Archived from the original on 17 April 2019. Retrieved 17 April 2019.*

20. *Tavano CL, Donohue TJ (Dec 2006).*

*"Development of the bacterial photosynthetic apparatus" . Current Opinion in Microbiology. 9 (6): 625–631. doi:10.1016/j.mib.2006.10.005 . PMC 2765710 . PMID 17055774 .*

21. *Mullineaux CW (1999). "The thylakoid membranes of cyanobacteria: structure, dynamics and function". Australian Journal of Plant Physiology. 26 (7): 671–677. doi:10.1071/PP99027 .*

22. Sener MK, Olsen JD, Hunter CN, Schulten K (Oct 2007). "Atomic-level structural and functional model of a bacterial photosynthetic membrane vesicle" . *Proceedings of the National Academy of Sciences of the United States of America*. **104** (40): 15723–15728.

*Bibcode:2007PNAS..10415723S* .

*doi:10.1073/pnas.0706861104* .

*PMC 2000399* . *PMID 17895378* .

23. *Campbell NA, Williamson B, Heyden RJ (2006). Biology Exploring Life . Upper Saddle River, NJ: Prentice Hall. ISBN 978-0-13-250882-7. Archived from the original on 2014-11-02. Retrieved 2009-02-03.*
24. *Ziehe D, Dünschede B, Schünemann D (Dec 2018). "Molecular mechanism of SRP-dependent light-harvesting protein transport to the thylakoid membrane in plants" . Photosynthesis Research. **138** (3): 303–313. doi:10.1007/s11120-018-0544-6 . PMC 6244792 . PMID 29956039 .*

25. *Raven PH, Evert RF, Eichhorn SE (2005). Biology of Plants (7th ed.). New York: W. H. Freeman and Company. pp. 124–127 . ISBN 978-0-7167-1007-3.*

26. *"Yachandra/Yano Group - Lawrence Berkeley National Laboratory" . [www2.lbl.gov](http://www2.lbl.gov). Archived from the original on 2019-07-22. Retrieved 2019-07-22.*

27. Pushkar Y, Yano J, Sauer K, Boussac A, Yachandra VK (Feb 2008). "Structural changes in the Mn<sub>4</sub>Ca cluster and the mechanism of photosynthetic water splitting" . *Proceedings of the National Academy of Sciences of the United States of America*. **105** (6): 1879–1884.

*Bibcode:2008PNAS..105.1879P* .

*doi:10.1073/pnas.0707092105* .

*PMC 2542863* . *PMID 18250316* .

28. Williams BP, Johnston IG, Covshoff S, Hibberd JM (September 2013).  
"Phenotypic landscape inference reveals multiple evolutionary paths to C<sub>4</sub> photosynthesis" . *eLife*. **2**: e00961.  
doi:10.7554/eLife.00961 .  
PMC 3786385 . PMID 24082995 .
29. Taiz L, Geiger E (2006). *Plant Physiology* (4th ed.). Sinauer Associates. ISBN 978-0-87893-856-8.
30. Monson RK, Sage RF (1999). "The Taxonomic Distribution of C<sub>4</sub> Photosynthesis" . *C<sub>4</sub> plant biology*. Boston: Academic Press. pp. 551–580. ISBN 978-0-12-614440-6.

31. *Dodd AN, Borland AM, Haslam RP, Griffiths H, Maxwell K (Apr 2002). "Crassulacean acid metabolism: plastic, fantastic". Journal of Experimental Botany. 53 (369): 569–580. doi:10.1093/jexbot/53.369.569 . PMID 11886877 .*
32. *Badger MR, Price GD (Feb 2003). "CO2 concentrating mechanisms in cyanobacteria: molecular components, their diversity and evolution". Journal of Experimental Botany. 54 (383): 609–622. doi:10.1093/jxb/erg076 . PMID 12554704 .*



33. *Badger MR, Andrews JT, Whitney SM, Ludwig M, Yellowlees DC, Leggat W, Price GD (1998). "The diversity and coevolution of Rubisco, plastids, pyrenoids, and chloroplast-based CO<sub>2</sub>-concentrating mechanisms in algae". Canadian Journal of Botany. **76** (6): 1052–1071. doi:10.1139/b98-074 .*

34. *Miyamoto K. "Chapter 1 – Biological energy production" . Renewable biological systems for alternative sustainable energy production (FAO Agricultural Services Bulletin – 128). Food and Agriculture Organization of the United Nations. Archived from the original on 7 September 2013. Retrieved 4 January 2009.*
35. *Maxwell K, Johnson GN (April 2000). "Chlorophyll fluorescence – a practical guide". Journal of Experimental Botany. 51 (345): 659–668. doi:10.1093/jexbot/51.345.659 . PMID 10938857 .*

36. Govindjee R. "What is Photosynthesis?" . *Biology at Illinois*. Archived from the original on 27 May 2014. Retrieved 17 April 2014.
37. Rosenqvist E, van Kooten O (2006). "Chapter 2: Chlorophyll Fluorescence: A General Description and Nomenclature" . In DeEll JA, Toivonen PM (eds.). *Practical Applications of Chlorophyll Fluorescence in Plant Biology*. Dordrecht, the Netherlands: Kluwer Academic Publishers. pp. 39–78.

38. *Baker NR, Oxborough K (2004).*

*"Chapter 3: Chlorophyll fluorescence as a probe of photosynthetic productivity" . In Papaqeorgiou G, Govindjee (eds.). Chlorophylla Fluorescence a Signature of Photosynthesis. Dordrecht, The Netherlands: Springer. pp. 66–79.*

39. *Flexas J, Escalnona JM, Medrano H*

*(January 1999). "Water stress induces different levels of photosynthesis and electron transport rate regulation in grapevines". Plant, Cell and Environment. **22** (1): 39–48.*

*doi:10.1046/j.1365-*

*3040.1999.00371.x .*

40. Fryer MJ, Andrews JR, Oxborough K, Blowers DA, Baker NR (1998).

*"Relationship between CO<sub>2</sub> assimilation, photosynthetic electron transport, and active O<sub>2</sub> metabolism in leaves of maize in the field during periods of low temperature" . Plant Physiology. **116** (2): 571–580. doi:10.1104/pp.116.2.571 . PMC 35114 . PMID 9490760 .*

41. *Earl H, Said Ennahli S (2004).*

*"Estimating photosynthetic electron transport via chlorophyll fluorometry without Photosystem II light saturation". Photosynthesis Research. **82** (2): 177–186. doi:10.1007/s11120-004-1454-3 . PMID 16151873 .*

42. *Genty B, Briantais J, Baker NR (1989).*

*"The relationship between the quantum yield of photosynthetic electron transport and quenching of chlorophyll fluorescence". Biochimica et Biophysica Acta (BBA) - General Subjects. **990** (1): 87–92. doi:10.1016/s0304-4165(89)80016-9 .*

43. Baker NR (2008). "Chlorophyll fluorescence: A probe of photosynthesis in vivo" . *Annual Review of Plant Biology*. **59**: 89–113. doi:10.1146/annurev.arplant.59.032607.092759 . PMID 18444897 .
44. Bernacchi CJ, Portis AR, Nakano H, von Caemmerer S, Long SP (2002). "Temperature response of mesophyll conductance. Implications for the determination of Rubisco enzyme kinetics and for limitations to photosynthesis in vivo" . *Plant Physiology*. **130** (4): 1992–1998. doi:10.1104/pp.008250 . PMC 166710 . PMID 12481082 .

45. Ribas-Carbo M, Flexas J, Robinson SA, Tcherkez GG (2010). "In vivo measurement of plant respiration". *University of Wollongong Research Online*.
46. Long SP, Bernacchi CJ (2003). "Gas exchange measurements, what can they tell us about the underlying limitations to photosynthesis? Procedures and sources of error". *Journal of Experimental Botany*. **54** (392): 2393–2401.  
*doi:10.1093/jxb/erg262* .  
*PMID 14512377* .



47. Bernacchi CJ, Portis A (2002). "R., Nakano H., von Caemmerer S., and Long S.P. (2002) Temperature response of mesophyll conductance. Implications for the determination of Rubisco enzyme kinetics and for limitations to photosynthesis in vivo" . *Plant Physiology*. **130** (4): 1992–1998. doi:10.1104/pp.008250 . PMC 166710 . PMID 12481082 .

48. Yin X, Struik PC (2009). "Theoretical reconsiderations when estimating the mesophyll conductance to  $\text{CO}_2$  diffusion in leaves of  $\text{C}_3$  plants by analysis of combined gas exchange and chlorophyll fluorescence measurements". *Plant, Cell and Environment*. **32** (11): 1513–1524 [1524]. doi:10.1111/j.1365-3040.2009.02016.x .  
PMID 19558403 .

49. Schreiber U, Klughammer C, Kolbowski J (2012). "Assessment of wavelength-dependent parameters of photosynthetic electron transport with a new type of multi-color PAM chlorophyll fluorometer" . *Photosynthesis Research*. **113** (1–3): 127–144. doi:10.1007/s11120-012-9758-1 . PMC 3430841 . PMID 22729479 .
50. Palmer J (21 June 2013). "Plants 'seen doing quantum physics' " . *BBC News*. Archived from the original on 3 October 2018. Retrieved 21 June 2018.

51. *Lloyd S (10 March 2014). "Quantum Biology: Better living through quantum mechanics" . The Nature of Reality. Nova: PBS Online; WGBH Boston. Archived from the original on 3 July 2017. Retrieved 8 September 2017.*
52. *Hildner R, Brinks D, Nieder JB, Cogdell RJ, van Hulst NF (June 2013). "Quantum coherent energy transfer over varying pathways in single light-harvesting complexes". Science. **340** (6139): 1448–1451. Bibcode:2013Sci...340.1448H . doi:10.1126/science.1235820 . PMID 23788794 .*

53. *Gale J (2009). Astrobiology of Earth: The emergence, evolution and future of life on a planet in turmoil . OUP Oxford. pp. 112–113. ISBN 978-0-19-154835-2.*
54. *Davis K (2 October 2004). "Photosynthesis got a really early start" . New Scientist. Archived from the original on 1 May 2015. Retrieved 8 September 2017.*
55. *Hooper R (19 August 2006). "Revealing the dawn of photosynthesis" . New Scientist. Archived from the original on 24 May 2015. Retrieved 8 September 2017.*

56. *Caredona, Tanai (6 March 2018). "Early Archean origin of heterodimeric Photosystem I" . Elsevier. 4 (3): e00548.*

*doi:10.1016/j.heliyon.2018.e00548 .*

*PMC 5857716 . PMID 29560463 .*

*Archived from the original on 1 April 2019. Retrieved 23 March 2018.*

57. *Howard V (7 March 2018).*

*"Photosynthesis Originated A Billion Years Earlier Than We Thought, Study Shows" . Astrobiology Magazine.*

*Retrieved 23 March 2018.*

58. Venn AA, Loram JE, Douglas AE (2008). "Photosynthetic symbioses in animals". *Journal of Experimental Botany*. **59** (5): 1069–1080. doi:10.1093/jxb/erm328 . PMID 18267943 .
59. Rumpho ME, Summer EJ, Manhart JR (May 2000). "Solar-powered sea slugs. Mollusc/algal chloroplast symbiosis" . *Plant Physiology*. **123** (1): 29–38. doi:10.1104/pp.123.1.29 . PMC 1539252 . PMID 10806222 .

60. Muscatine L, Greene RW (1973).

*Chloroplasts and algae as symbionts in molluscs. International Review of Cytology.* **36.** pp. 137–169.

*doi:10.1016/S0074-7696(08)60217-X .*

*ISBN 978-0-12-364336-0.*

*PMID 4587388 .*



61. Rumpho ME, Worful JM, Lee J, Kannan K, Tyler MS, Bhattacharya D, Moustafa A, Manhart JR (Nov 2008). "Horizontal gene transfer of the algal nuclear gene *psbO* to the photosynthetic sea slug *Elysia chlorotica*" . *Proceedings of the National Academy of Sciences of the United States of America*. **105** (46): 17867–17871.

*Bibcode*:2008PNAS..10517867R .

*doi*:10.1073/pnas.0804968105 .

*PMC* 2584685 . *PMID* 19004808 .

62. Douglas SE (Dec 1998). "Plastid evolution: origins, diversity, trends". *Current Opinion in Genetics & Development*. **8** (6): 655–661. doi:10.1016/S0959-437X(98)80033-6 . PMID 9914199 .
63. Reyes-Prieto A, Weber AP, Bhattacharya D (2007). "The origin and establishment of the plastid in algae and plants" . *Annual Review of Genetics*. **41**: 147–168. doi:10.1146/annurev.genet.41.110306.130134 . PMID 17600460 .

64. Raven JA, Allen JF (2003). "Genomics and chloroplast evolution: what did cyanobacteria do for plants?" .  
*Genome Biology*. **4** (3): 209.  
doi:10.1186/gb-2003-4-3-209 .  
PMC 153454 . PMID 12620099 .
65. Allen JF (December 2017). "The CoRR hypothesis for genes in organelles". *J. Theor. Biol.* **434**: 50–57.  
doi:10.1016/j.jtbi.2017.04.008 .  
PMID 28408315 .

66. Tomitani A, Knoll AH, Cavanaugh CM, Ohno T (Apr 2006). "The evolutionary diversification of cyanobacteria: molecular-phylogenetic and paleontological perspectives" . *Proceedings of the National Academy of Sciences of the United States of America*. **103** (14): 5442–5447. *Bibcode*:2006PNAS..103.5442T . *doi*:10.1073/pnas.0600999103 . *PMC* 1459374 . *PMID* 16569695 .
67. "Cyanobacteria: Fossil Record" . *Ucmp.berkeley.edu*. Archived from the original on 2010-08-24. Retrieved 2010-08-26.

68. *Smith A (2010). Plant biology . New York: Garland Science. p. 5. ISBN 978-0-8153-4025-6.*
69. *Herrero A, Flores E (2008). The Cyanobacteria: Molecular Biology, Genomics and Evolution (1st ed.). Caister Academic Press. ISBN 978-1-904455-15-8.*
70. *Eugene Rabinowitch (1945) Photosynthesis and Related Processes via Biodiversity Heritage Library*

71. Walker DA (2002). " 'And whose bright presence' – an appreciation of Robert Hill and his reaction" (PDF).

*Photosynthesis Research.* **73** (1–3): 51–54.

doi:10.1023/A:1020479620680 .

PMID 16245102 . Archived (PDF)

from the original on 2008-03-09.

Retrieved 2015-08-27.

72. Otto Warburg – Biography Archived 2010-12-15 at the Wayback Machine.

Nobelprize.org (1970-08-01). Retrieved on 2011-11-03.

73. Kandler O (1950). "Über die Beziehungen zwischen Phosphathaushalt und Photosynthese. I. Phosphatspiegelschwankungen bei *Chlorella pyrenoidosa* als Folge des Licht-Dunkel-Wechsels" [On the relationship between the phosphate metabolism and photosynthesis I. Variations in phosphate levels in *Chlorella pyrenoidosa* as a consequence of light-dark changes] (PDF). *Zeitschrift für Naturforschung*. **5b** (8): 423–437. doi:10.1515/znb-1950-0806 . Archived (PDF) from the original on 2018-06-24. Retrieved 2018-06-26.

74. Arnon DI, Whatley FR, Allen MB (1954). "Photosynthesis by isolated chloroplasts. II. Photophosphorylation, the conversion of light into phosphate bond energy". *Journal of the American Chemical Society*. **76** (24): 6324–6329. doi:10.1021/ja01653a025 .

75. Arnon DI (1956). "Phosphorus metabolism and photosynthesis". *Annual Review of Plant Physiology*. **7**: 325–354.  
doi:10.1146/annurev.pp.07.060156.001545 .



76. Gest H (2002). "History of the word photosynthesis and evolution of its definition". *Photosynthesis Research*. **73** (1–3): 7–10.

doi:10.1023/A:1020419417954 .

PMID 16245098 .

77. Calvin M (July 1989). "Forty years of photosynthesis and related activities". *Photosynthesis Research*. **21** (1): 3–16. doi:10.1007/BF00047170 (inactive 2020-05-25).

PMID 24424488 .

78. Verduin J (1953). "A table of photosynthesis rates under optimal, near natural conditions". *Am. J. Bot.* **40** (9): 675–679. doi:10.1002/j.1537-2197.1953.tb06540.x .  
JSTOR 2439681 .
79. Verduin J, Whitwer EE, Cowell BC (1959). "Maximal photosynthetic rates in nature". *Science*. **130** (3370): 268–269. Bibcode:1959Sci...130..268V .  
doi:10.1126/science.130.3370.268 .  
PMID 13668557 .

80. Hesketh JD, Musgrave R (1962).

*"Photosynthesis under field conditions. IV. Light studies with individual corn leaves"* . *Crop Sci.* **2** (4): 311–315.

doi:10.2135/cropsci1962.0011183x000200040011x .

81. Hesketh JD, Moss DN (1963).

*"Variation in the response of photosynthesis to light"*. *Crop Sci.* **3** (2): 107–110.

doi:10.2135/cropsci1963.0011183X000300020002x .

82. *El-Sharkawy, MA, Hesketh JD (1965). "Photosynthesis among species in relation to characteristics of leaf anatomy and CO<sub>2</sub> diffusion resistances". Crop Sci. 5 (6): 517–521. doi:10.2135/cropsci1965.0011183x000500060010x .*
83. *El-Sharkawy MA, Hesketh JD (1986). "Citation Classic-Photosynthesis among species in relation to characteristics of leaf anatomy and CO<sub>2</sub> diffusion resistances" (PDF). Curr. Cont./Agr.Biol.Environ. 27: 14.*
84. *Haberlandt G (1904). Physiologische Pflanzenanatomie . Leipzig: Engelmann.*

85. *El-Sharkawy MA (1965). Factors Limiting Photosynthetic Rates of Different Plant Species (Ph.D. thesis). The University of Arizona, Tucson, USA.*
86. *Karpilov YS (1960). "The distribution of radioactivity in carbon-14 among the products of photosynthesis in maize". Proc. Kazan Agric. Inst. 14: 15–24.*
87. *Kortschak HP, Hart CE, Burr GO (1965). "Carbon dioxide fixation in sugarcane leaves" . Plant Physiol. 40 (2): 209–213. doi:10.1104/pp.40.2.209 . PMC 550268 . PMID 16656075 .*

88. Hatch MD, Slack CR (1966).

*"Photosynthesis by sugar-cane leaves.  
A new carboxylation reaction and the  
pathway of sugar formation" .*

*Biochem. J. **101** (1): 103–111.*

*doi:10.1042/bj1010103 .*

*PMC 1270070 . PMID 5971771 .*

89. Chapin FS, Matson PA, Mooney HA

*(2002). Principles of Terrestrial*

*Ecosystem Ecology . New York:*

*Springer. pp. 97–104. ISBN 978-0-387-*

*95443-1.*

90. Jones HG (2014). *Plants and Microclimate: a Quantitative Approach to Environmental Plant Physiology* (Third ed.). Cambridge: Cambridge University Press. ISBN 978-0-521-27959-8.

## Further reading

---

### Books

- Bidlack JE, Stern KR, Jansky S (2003). *Introductory Plant Biology*. New York: McGraw-Hill. ISBN 978-0-07-290941-8.
- Blankenship RE (2014). *Molecular Mechanisms of Photosynthesis* (2nd ed.). John Wiley & Sons. ISBN 978-1-4051-8975-0.

- Govindjee, Beatty JT, Gest H, Allen JF (2006). *Discoveries in Photosynthesis* . Advances in Photosynthesis and Respiration. **20**. Berlin: Springer. ISBN 978-1-4020-3323-0.
- Reece JB, et al. (2013). *Campbell Biology*. Benjamin Cummings. ISBN 978-0-321-77565-8.

## Papers

- Gupta RS, Mukhtar T, Singh B (Jun 1999). "Evolutionary relationships among photosynthetic prokaryotes (*Heliobacterium chlorum*, *Chloroflexus aurantiacus*, cyanobacteria, *Chlorobium tepidum* and proteobacteria): implications regarding the origin of photosynthesis". *Molecular Microbiology*. **32** (5): 893–906.



[doi:10.1046/j.1365-2958.1999.01417.x](https://doi.org/10.1046/j.1365-2958.1999.01417.x) .

[PMID 10361294](https://pubmed.ncbi.nlm.nih.gov/10361294/) .

- Rutherford AW, Faller P (Jan 2003).  
["Photosystem II: evolutionary perspectives"](#) .  
*Philosophical Transactions of the Royal Society of London. Series B, Biological Sciences.* **358** (1429): 245–253.  
[doi:10.1098/rstb.2002.1186](https://doi.org/10.1098/rstb.2002.1186) .  
[PMC 1693113](https://pubmed.ncbi.nlm.nih.gov/1693113/) . [PMID 12594932](https://pubmed.ncbi.nlm.nih.gov/12594932/) .

## External links

---

- [A collection of photosynthesis pages for all levels from a renowned expert \(Govindjee\)](#).
- [In depth, advanced treatment of photosynthesis, also from Govindjee](#)

- Science Aid: Photosynthesis Article appropriate for high school science
- Metabolism, Cellular Respiration and Photosynthesis – The Virtual Library of Biochemistry and Cell Biology.
- Overall examination of Photosynthesis at an intermediate level
- Overall Energetics of Photosynthesis
- Photosynthesis Discovery Milestones – experiments and background
- The source of oxygen produced by photosynthesis Interactive animation, a textbook tutorial
- Marshall J (2011-03-29). "First practical artificial leaf makes debut" . Discovery

News.

- Photosynthesis – Light Dependent & Light Independent Stages
- Khan Academy, video introduction
- Ehrenberg R (2017-12-15). "The photosynthesis fix". Knowable Magazine.

Retrieved from

["https://en.wikipedia.org/w/index.php?title=Photosynthesis&oldid=965124407"](https://en.wikipedia.org/w/index.php?title=Photosynthesis&oldid=965124407)

---

Last edited 11 days ago by InternetArchiveBot

Content is available under CC BY-SA 3.0 unless otherwise noted.