

UNIT-I

1.1 STRUCTURE OF POWER SYSTEMS—

A typical power system can be divided into different parts. These are generation, transmission and distribution systems.

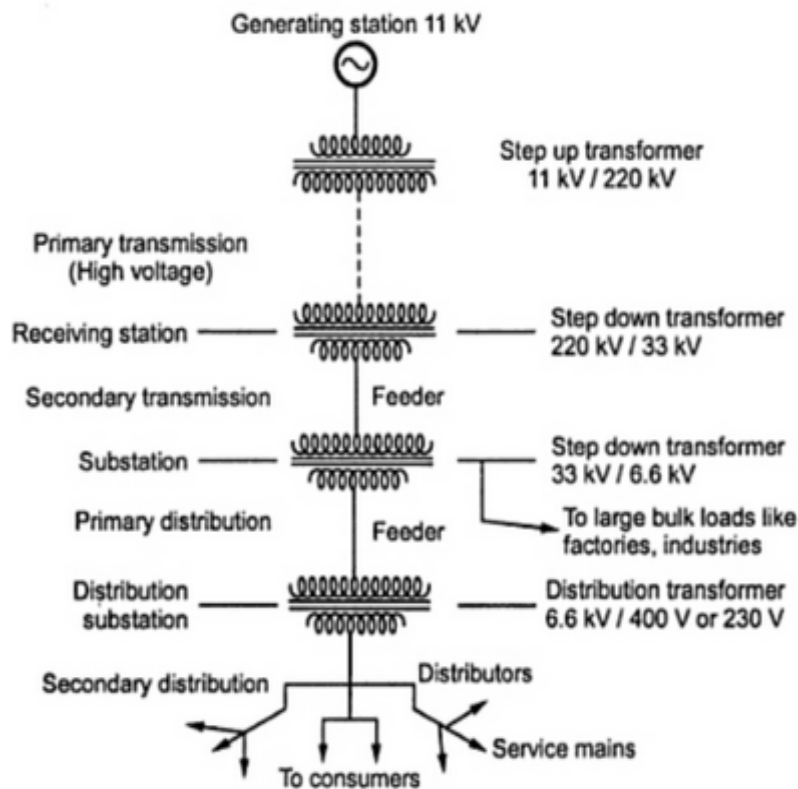

At present, the vertically integrated utilities (state electricity boards) can import or export a pre-decided amount of power from neighboring states or generators owned by other entities like National Thermal Power Corporation or independent power producers(IPP).

Individual power systems are arranged in the form of electrically connected areas known as power pools or regional grids, which cover a particular region. These regional grids are interconnected through tie lines to form a national grid. By this arrangement each area is contractually tied to other areas in respect to generation and scheduling features.

1.2 SCADA SYSTEM-

In SCADA system measured values, i.e. analogue (measured value) data (MW, MVAR, V, Hz Transformer tap position), and Open/Closed status information, i.e. digital data (Circuit Breakers/Isolators position i.e. on/off status), are transmitted through telecommunication channels to respective sub-LDCs. Secondary side of Current Transformers (CT) and Potential Transformer (PT) are connected with 'Transducers'. The output of transducers is available in dc current form (in the range of 4mA to 20mA). A/D converter converts this current into binary pulses. Different inputs are interleaved in a sequential form and are fed into the CPU of the RTU. The output of RTU, containing information in the form of digital pulses, is sent to sub LDC. At sub LDC end, data received from RTU is fed into the data servers. In general, a SCADA system consists of a database, displays and supporting programmes. The brief overview of major 'functional areas' of SCADA system is as below:

1. **Communications** - Sub-LDC's computer communicates with all RTU stations under its control, through a communication system. RTU polling, message formatting, polynomial checking and message retransmission on failure are the activities of 'Communications' functional area.
2. **Data Processing** - After receipt of data through communication system it is processed. Data process function has three sub-functions i.e. (i) Measurements, (ii) Counters and (iii) Indications.
 - '*Measurements*' retrieved from a RTU are converted to engineering units and linearised, if necessary. The measurement are then placed in database and are checked against various limits which if exceeded generate high or low limit alarms.
 - The system has been set-up to collect '*Counters*' at regular intervals: typically 5 or 10 minutes. At the end of the hour the units is transferred into appropriate hour slot in a 24-hour archive/history.
 - '*Indications*' are associated with status changes and protection. For those statuses that are not classified as 'alarms', logs the change on the appropriate printer and also enter it into a cyclic event list. For those statuses, which are defined as an 'alarms' and the indication goes into alarm, an entry is made into the appropriate alarm list, as well as in the event list and an audible alarm is generated in the sub-LDC.
3. **Alarm/Event Logging** - The alarm and event logging facilities are used by SCADA data processing system. Alarms are grouped into different categories and are given different priorities. Quality codes are assigned to the recently received data for any 'limit violation' and 'status changes'. Alarms are acknowledged from single line diagram (or alarm lists) on display terminal in LDCs.

4. **Manual Entry** - There is a provision of manual entry of measured values, counters and indications for the important sub-station/powerhouse, which are uncovered by an RTU or some problem is going on in its RTU, equipment, communication path, etc.
5. **Averaging of Measured Values** - As an option, the SCADA system supports averaging of all analogue measurements. Typically, the averaging of measured values over a period of 15 minutes is stored to provide 24 hours trend.
6. **Historical Data Recording (HDR)** - The HDR, i.e. 'archive', subsystem maintains a history of selected system parameters over a period of time. These are sampled at a pre-selected interval and are placed in historical database. At the end of the day, the data is saved for later analysis and for report generation.
7. **Interactive Database Generation** - Facilities have been provided in such a way that an off-line copy of the SCADA database can be modified allowing the addition of new RTUs, pickup points and communication channels.
8. **Supervisory Control/Remote Command** - This function enables the issue of 'remote control' commands to the sub-station/powerhouse equipment e.g. circuit breaker trip command.
9. **Fail-over** - A 'Fail-over' subsystem is also provided to secure and maintain a database of devices and their backups. The state of the device is maintained indicating whether it is 'on-line' or 'failed'. There is a 'backup' system, which maintains database on a backup computer and the system is duplicated.

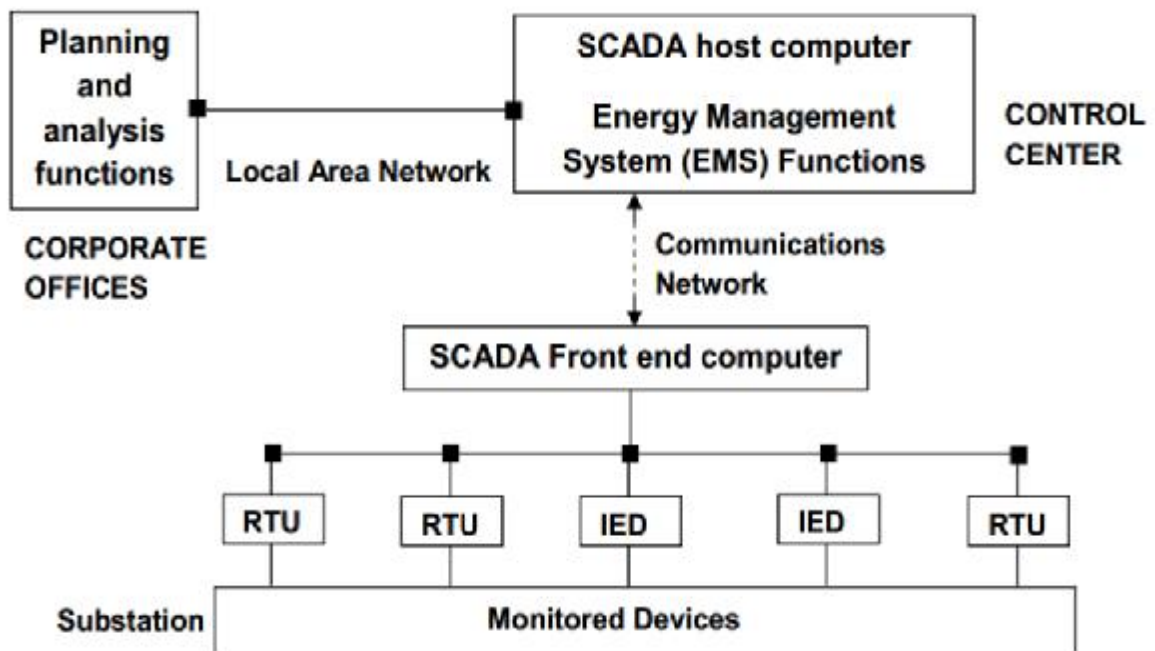

ENERGY MANAGEMENT SYSTEM (EMS) & REAL TIME COMPUTER-CONTROL-

For energy management of the power system, control personnel and application software engineers use SCADA data available in the database by using EMS software. Important features are as below:

1. The Data Base Compiler provides a consistent source of data usable for the applications in an efficient form. The Data Base Compiler does final checking for completeness and consistency of the entries for a specific application and prepares those special tables which are needed for the efficiency of specific application programmes.
2. Recording of 'Sequence of Events' (SOEs) is the most innovative feature provided in this system. A RTU has the ability to accurately time tag status change and report this information to sub-LDC. All RTUs in the system are 'time synchronized' with the master station. In the event of any tripping, sequence of events can be well established on time scale with a resolution of 10 milliseconds.
3. Normally, 'Automatic Generation Control' (AGC) function issues control commands to generating plants using the concept of Area Control Error (ACE). It is based on deviations in 'standard frequency (50 Hz)' and 'scheduled area interchanges' from that of the 'actual frequency' and 'actual area interchanges' In the event of unavailability of sufficient generation to satisfy the AGC requirement, the System Control Officer can enforce required quantum of load shedding.
4. For 'Operation Scheduling' the application software has 'short-term' and 'long-term' 'System Load Forecasting' functions to assist dispatching Engineer/control Officer in estimating the loads that are expected to exist for one to several days in advance. This function provides a scientific and logical way of scheduling of resources in a very effective manner.
 - Under 'Short-term Load Forecasting' function, application software engineers are able to forecast weekly peak demands and load duration curves for several months into the future.
 - Under 'Long-Term Load Forecasting' function, forecasting of monthly peak demands and load duration curves for several years into the future can done for the use of 'Power System Planner'.
5. The other functions like economic dispatch, reserve monitoring, production costing, inter system transactions scheduling, etc. are available to guide System Control Officer to optimally use available resources.
6. Power System Control Officer/Analyst would be able to use contingency analysis function to assess the impact of specified contingencies that would cause line (s) overloads, abnormal voltages, and reactive limit violations.

7. The EMS software system may have many other applications for use, which include network topology, performing of state estimation, optimal power flow (OPF) programme, stability programme, power flow displays, help and instructional displays, tabular displays, single line diagram displays, etc.

1.3 LEVEL DECOMPOSITION IN POWER SYSTEM-

A hierarchy of Control centers has been formed---

In the diagram National Load Dispatch Centre (NLDC) has been shown at the top. Its Control Centre has been setup at New Delhi and became operational in January 2014. Below this, five nos. regional level Load Dispatch Centers have been shown. The role of the NLDC is to monitor and supervise the grid and power generation of the region. It focuses attention on the regional interconnected network. By using 'Energy Management System' (EMS) and advanced application programmes, NLDC coordinates with all inter-region and inter-state power exchange.

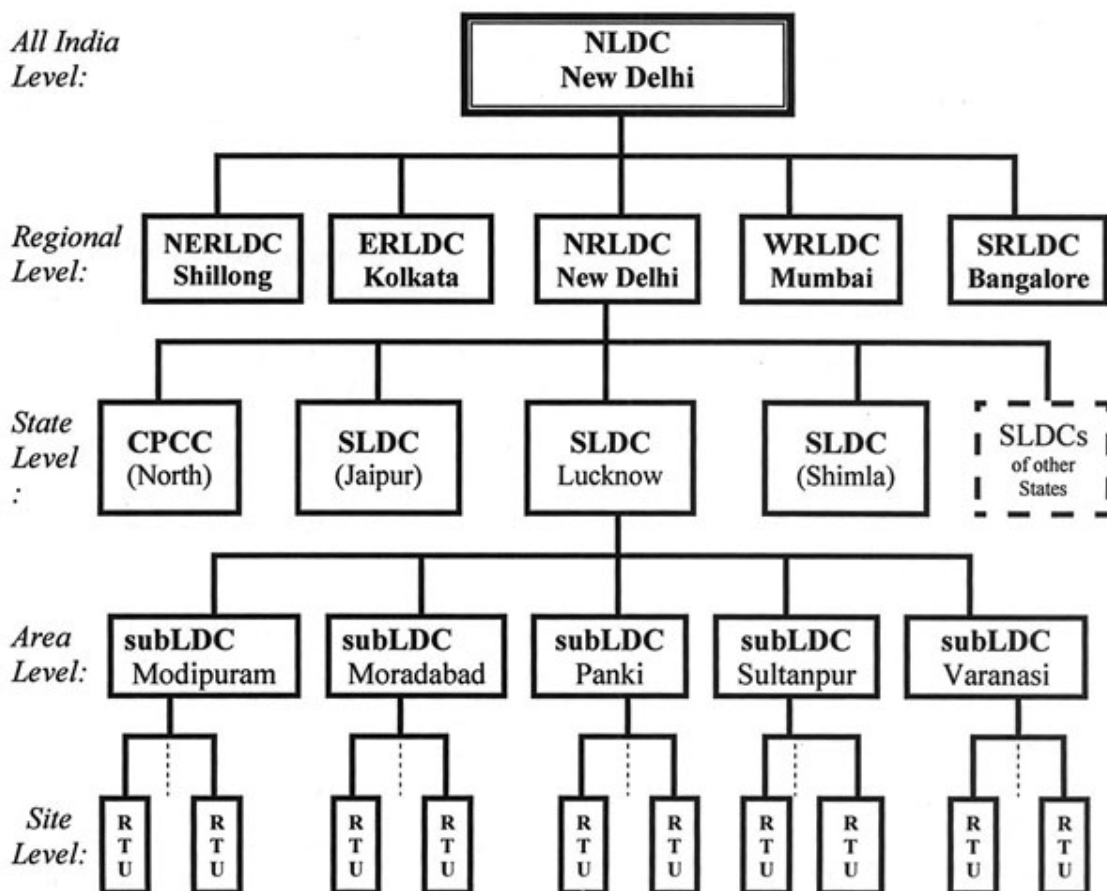

Hierarchical Structure of Power System Control Centres

Below NRLDC, State level SLDCs and Central Project Coordination & Control Centre (CPCC) have been shown. The primary role of SLDCs is to monitor, control and coordinate the generation, transmission and distribution of power within the State while ensuring safety and continuity of its transmission and sub-transmission power networks. CPCC (North) coordinates with all Central sector projects of northern region such as those of NTPC, NHPC, Power Grid, Tehri, etc. CPCC gets data from Central Sector projects and that data is added at regional level. Each RLDC has the ability to exchange data with other RLDCs as well as with NLDC, but direct data transmission does not take place between SLDC of one State with SLDC of another State.

1.4 POWER SYSTEM SECURITY –

Power system security is defined as the probability of the system's operating point remaining within acceptable ranges, given the probabilities of changes in the system (contingencies). Normal operating condition usually means that all the apparatus are running within their prescribed limits, and all the system variables are within acceptable ranges. The system should also continue to operate 'normally' even in the case of credible contingencies. The operator should 'foresee' such contingencies (disturbances) and take preventive control actions (as economically as possible) such that the system integrity and quality of power supply is maintained.

Major components of security assessment:

(1) System monitoring (2) Contingency analysis (3) Preventive and corrective actions

(1) System monitoring: Monitoring the system is the first step. Measurement devices dispersed throughout the system help in getting a picture of the current operating state. The measurements can be in the form of power injections, power flows, voltage, current, status of circuit breakers, switches, transformer taps, generator output etc., which are telemetered to the control centre. Usually a state estimator is used in the control centre to process these telemetered data and compute the best estimates of the system states. Remote control of the circuit breakers, disconnector switches, transformer taps etc. is generally possible.

(2) Contingency analysis: Once the current operating state is known, next is the contingency analysis. Results of contingency analysis allow the system to be operated defensively. Major components of contingency analysis are:

Contingency definition, Contingency selection and Contingency evaluation

(3) Preventive and corrective actions: Preventive and corrective actions are needed to maintain a secure operation of a system or to bring it to a secure operating state. Corrective actions such as switching of VAR compensating devices, changing transformer taps and phase shifters etc. are mainly automatic in nature, and involve short duration. Preventive actions such as generation rescheduling involve longer time scales. Security-constrained optimal power flow is an example of rescheduling the generations in the system in order to ensure a secure system operation.

1.5 VARIOUS OPERATIONAL STAGES OF POWER SYSTEM—

A *normal* (secure) state is the ideal operating condition, wherein all the equipment are operating within their design limits. Also, the power system can withstand a contingency without violation of any of the constraints. The system is said to be in the *alert* (insecure) state, if voltage and frequency are reaching beyond the specified limits. The system is "weaker" and may not be able to withstand a contingency. Preventive Control actions like shifting generation (re-scheduling), load shedding are required to get the system back to the normal state.

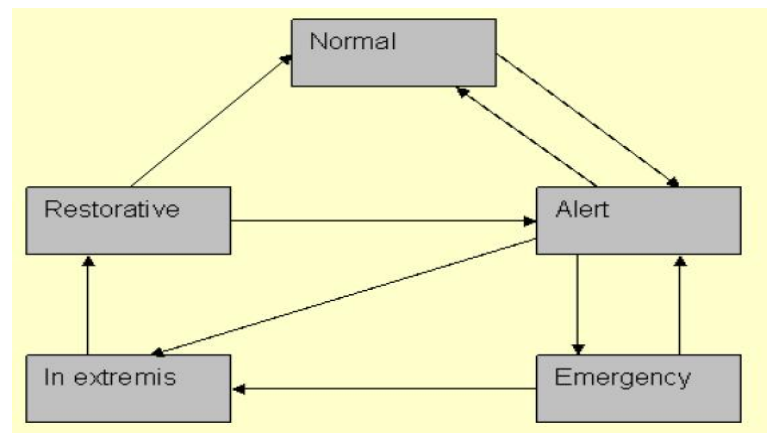

If preventive control actions do not succeed, a power system remains insecure (in the alert state). If a *contingency* occurs, the system may go into the *emergency* state where overloading of equipment (above the short term ratings of the equipment) occurs. The system can still be intact and can be brought back to the alert state by Emergency Control actions like fault tripping, generator tripping, load tripping, HVDC power control etc. If these measures do not work, integrated system operation becomes unviable and a major part of the system may be shutdown due to equipment outages. Load shedding and islanding is necessary to prevent spreading of disturbances and a total grid failure. The small power systems (islands) are reconnected to restore the power system to normal state (Restorative Control).

1.6 POWER SYSTEM VOLTAGE STABILITY-

Voltage Instability occurs under heavy loading conditions. This problem causes extremely low voltages below acceptable limits. As the load resistance decreases, the voltage at the load bus falls while power is expected to increase. However, a point comes beyond which the load power decreases as resistance falls.

Normally, a power system has connected loads which are lesser than the maximum power transfer capability of the generation and transmission network. However, loss of lines may significantly increase transmission reactance. Generators may also hit their reactive capability

limits resulting in inability to maintain voltage at key points in the network. A stronger transmission network and adequate reactive power reserves, to maintain voltages at key points in the network, are needed to avoid voltage instability.

Small-disturbance Voltage Stability-A power system at a given operating state is small-disturbance voltage stable if, following any small disturbance, voltages near loads are close to the pre-disturbance values. The concept of small-disturbance voltage stability is related to steady-state stability and can be analyzed using small signal (linearized) model of the system.

Voltage Stability-A power system at a given operating state and subjected to a given disturbance is voltage stable if voltages near loads approach post-disturbance equilibrium values. The concept of voltage stability is related to transient stability of a power system.

Voltage Collapse-Following voltage instability, a power system undergoes voltage collapse if the post-disturbance equilibrium voltages near loads are below acceptable limits. Voltage collapse may be total (blackout) or partial. The absence of voltage stability leads to voltage instability and results in progressive decrease of voltages. Thus abnormal voltage levels in steady state may be the result of voltage instability which is a dynamic phenomenon. The voltage instability and collapse may occur in a time frame of fraction of a second. In this case the term 'transient voltage stability' is used.

Control of Voltage Instability- Voltage instability along with angle instability pose a threat to the system security. Uncontrolled load rejection due to voltage collapse can cause system separation and blackouts. Hence the system must be planned in such a way as to reduce the possibility of voltage instability. Also the system must be operated with adequate margin for voltage stability. In the event of voltage instability due to unforeseen contingencies, the system - control must prevent widespread voltage collapse and restore the loads as quickly as possible. The incidence of voltage instability increases as the system is operated close to its maximum load stability limit.

Countermeasures for the problem:

- (1) The reactive power compensation close to the load centers as well as at the critical buses in the network is essential for overcoming voltage instability.
- (2) The SVC and STATCON provide fast control and help improve system stability.
- (3) The application of under voltage load shedding, controlled system separation and adaptive Q intelligent control are steps in this direction.
- (4) Use of OLTC.

UNIT-II

2.1 UNIT COMMITMENT-

To “commit” a generating unit means to “turn it on;” that is, to bring the unit up to speed, synchronize it to the system, and connect it so that it can deliver power to the network. The problem with “commit enough units and leave them on line” is one of economics. Money can be saved by turning units off (decommitting them) when they are not needed. Many constraints can be placed on the unit commitment problem. Constraints are:

- Spinning Reserve
- Thermal Unit Constraints: In these the different constraints are as:
Minimum up time: once the unit is running, it should not be turned off immediately.

Minimum down time: once the unit is decommitted, there is a minimum time before it can be recommitted.

Crew constraints: if a plant consists of two or more units, they cannot both be turned on at the same time since there are not enough crew members to attend both units while starting up.

- Fuel Constraints

The solution methods of the unit commitment problem are:

Priority-list schemes,
 Dynamic programming (DP),
 Lagrange relaxation (LR).

2.2 INPUT-OUTPUT CHARACTERISTICS OF THERMAL PLANTS-

Input-Output Curve

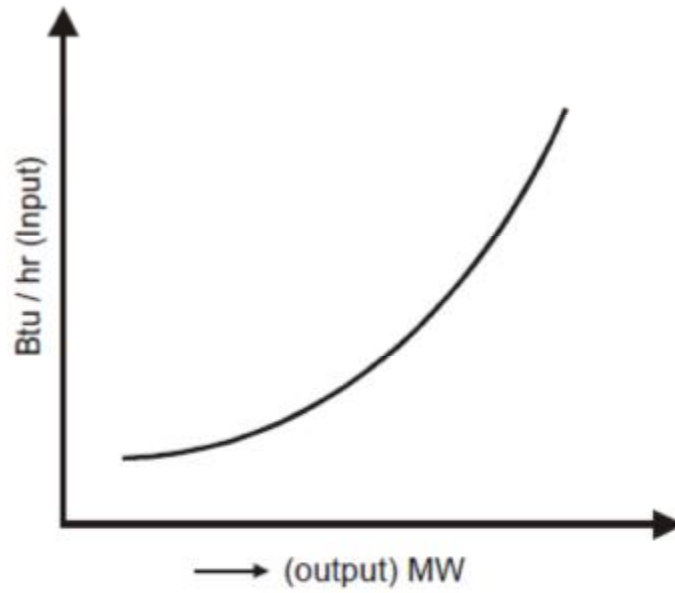

Heat Rate Curve

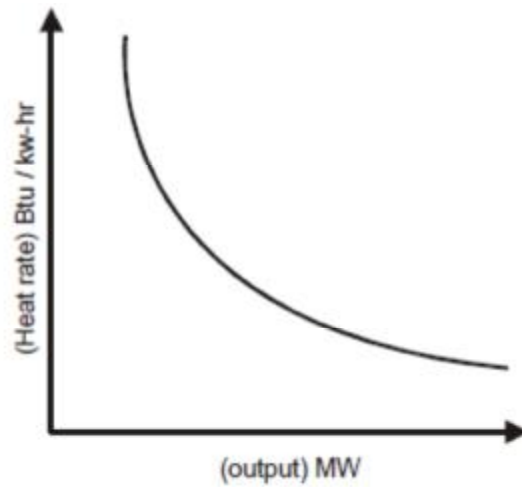

Incremental Fuel Rate Curve

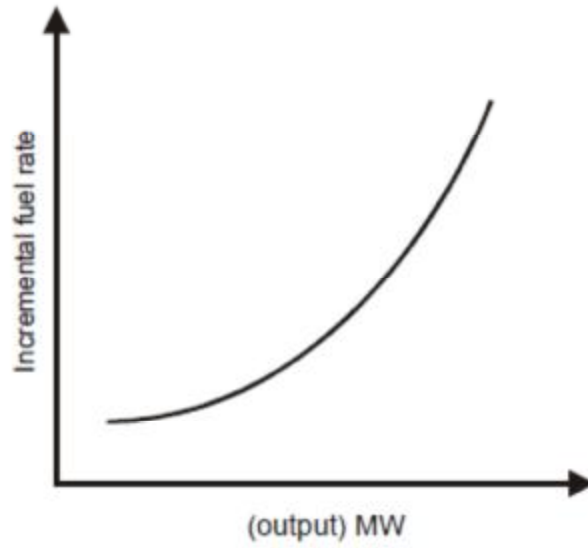

Incremental Cost Curve

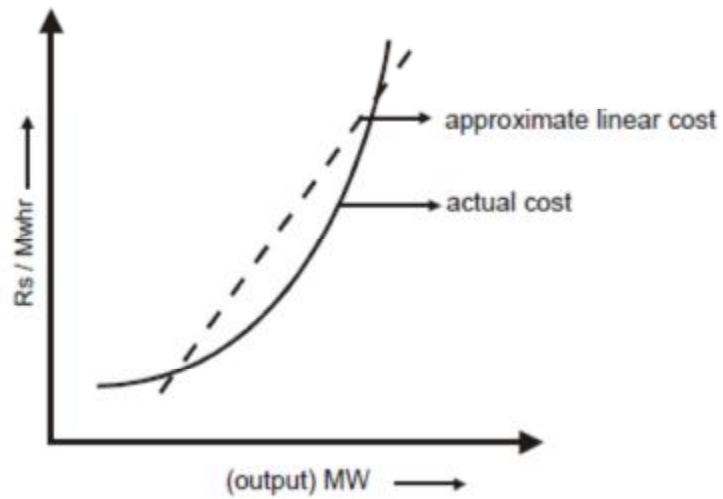

Input-output characteristics of Hydro Plants:

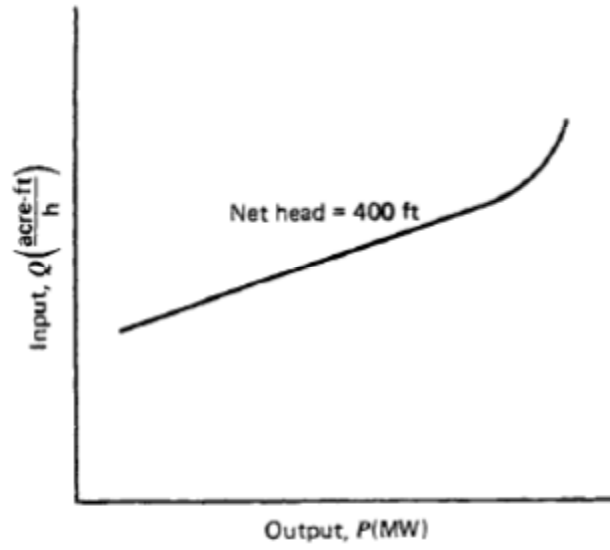

Incremental Water Rate Characteristic

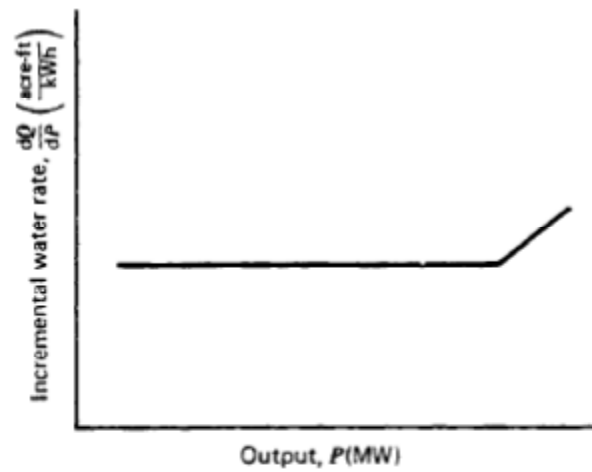

Input-Output characteristic for different head plants

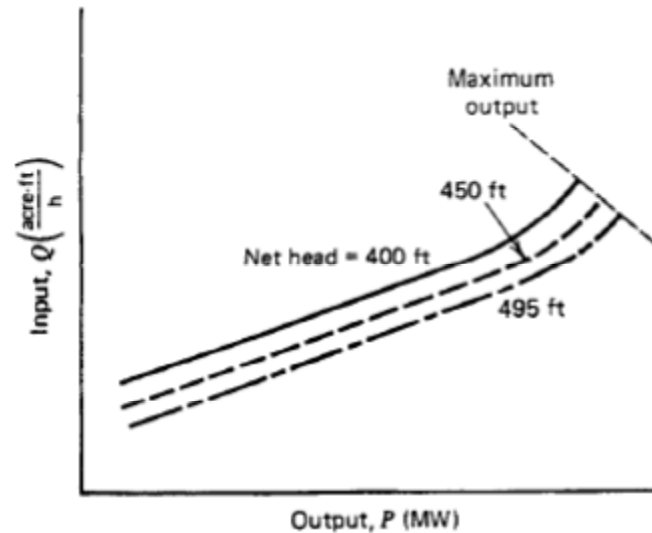

2.3 SYSTEM CONSTRAINTS-

1. Primary constraints (equality constraints):

Power balance equations:

$P_i - P_{Di} - P_l = 0$; $Q_i - Q_{Di} - Q_l = 0$; i =buses of the system, real and reactive power flow are P_l and Q_l .

The above constraints arise due to the need for the system to balance the generation and load demand of the system.

2. Secondary constraints (inequality constraints):

These arise due to physical and operational limitations of the units and components.

$$P_i^{\min} \leq P_i \leq P_i^{\max}$$

$$Q_i^{\min} \leq Q_i \leq Q_i^{\max}$$

$i = 1, 2, \dots, n$, the number of generating units in the system.

3. Spare Capacity Constraints:

These are used to account for the errors in load prediction, any sudden or fast change in load demand, inadvertent loss of scheduled generation, etc. Here, the total generation available at any time should be in excess of the total anticipated load demand and any system loss by an amount not less than a specified minimum spare capacity, P_{SP} (called the Spinning Reserve) given by:

$$P_{IG}(\text{Generation}) \geq \Sigma P_l(\text{Losses}) + P_{SP} + P_{Dj}(\text{Load})$$

4. Bus voltage and Bus angle Constraints:

Bus voltage and Bus angle Constraints are needed to maintain a flat bus voltage profile and to limit the overloading respectively.

$$V_i^{\min} \leq V_i \leq V_i^{\max} \quad i = 1, 2, \dots, n$$

$$\delta_i^{\min} \leq \delta_i \leq \delta_i^{\max} \quad i = 1, 2, \dots, n; j = 1, 2, \dots, m$$

Spinning Reserve:

Spinning reserve (SR) is the term used to describe the total amount of generation available from all the synchronized (spinning) units of the system minus the present load plus the losses being supplied. i.e.,

$$P_{sp} = (\text{Total Generation, } \Sigma P_{IG}) - (\Sigma P_l (\text{losses}) + \Sigma P_{Dj} (\text{Load}))$$

The SR must be made available in the system so that the loss of one or more units does not cause a large drop in system frequency. SR must be allocated to different units. SR must be capable of making up for the loss of the most heavily loaded unit in the system.

2.4 OPTIMAL OPERATION OF THERMAL UNITS WITHOUT AND WITH TRANSMISSION LOSSES

When transmission losses are neglected. The model does not consider the system configuration or line impedances. Since losses are neglected, the total generation is equal to the total demand P_D . Consider a system with n_g number of generating plants supplying the total demand P_D . If F_i is the cost of plant i in Rs/h, the mathematical formulation of the problem of economic scheduling can be stated as follows:

$$\text{Minimize } F_T = \sum_{i=1}^{n_g} F_i$$

$$\text{Such that } \sum_{i=1}^{n_g} P_{G_i} = P_D$$

where F_T = total cost

P_{G_i} = generation of plant i , P_D = total demand

The augmented cost function is given by,

$$L = F_T + \lambda \left(P_D - \sum_{i=1}^{n_g} P_{G_i} \right)$$

Minimum F_T is obtained when,

$$\frac{\partial L}{\partial P_{G_i}} = 0 \quad \text{and} \quad \frac{\partial L}{\partial \lambda} = 0$$

$$\frac{\partial L}{\partial P_{G_i}} = \frac{\partial F_T}{\partial P_{G_i}} - \lambda = 0$$

$$\frac{\partial L}{\partial \lambda} = P_D - \sum_{i=1}^{n_g} P_{G_i} = 0$$

F_i depends only on its own output P_{G_i} , hence

$$\frac{\partial F_T}{\partial P_{G_i}} = \frac{\partial F_i}{\partial P_{G_i}} = \frac{dF_i}{dP_{G_i}}$$

$$\frac{\partial F_i}{\partial P_{G_i}} = \frac{dF_i}{dP_{G_i}} = \lambda ; \quad i = 1, \dots, n_g$$

For economic generation scheduling to meet a particular load demand, when transmission losses are neglected and generation limits are not imposed, all plants must operate at equal incremental production costs, subject to the constraint that the total generation be equal to the demand.

2.6 INCREMENTAL TRANSMISSION LOSS, TRANSMISSION LOSS FORMULA (WITHOUT DERIVATION) :

The mathematical formulation is now stated as

$$\text{Minimize } F_T = \sum_{i=1}^{n_g} F_i$$

$$\text{Such that } \sum_{i=1}^{n_g} P_{G_i} = P_D + P_L ; \quad \text{where } P_L \text{ is the total loss}$$

$$\text{Cost function } L = F_T - \lambda \left(\sum_{i=1}^{n_g} P_{G_i} - P_D - P_L \right)$$

The minimum point is obtained when,

$$\frac{\partial L}{\partial P_{G_i}} = \frac{\partial F_T}{\partial P_{G_i}} - \lambda \left(1 - \frac{\partial P_L}{\partial P_{G_i}} \right) = 0 ; i = 1, \dots, n_g$$

$$\frac{\partial L}{\partial \lambda} = \sum_{i=1}^{n_g} P_{G_i} - P_D + P_L = 0$$

$$\frac{\partial F_T}{\partial P_{G_i}} = \frac{dF_i}{dP_{G_i}}$$

$$\frac{dF_i}{dP_{G_i}} + \lambda \frac{\partial P_L}{\partial P_{G_i}} = \lambda$$

The term $\frac{1}{1 - \frac{\partial P_L}{\partial P_{G_i}}}$ is called the penalty factor of plant i , L_i . The coordination equation

including losses are given by $\lambda = \frac{dF_i}{dP_{G_i}} L_i ; i = 1, \dots, n_g$

The minimum operation cost is obtained when the product of the incremental fuel cost and the penalty factor of all units is the same, when losses are considered.

Expression for loss P_L is given by, $P_L = \sum_m \sum_n P_{G_m} B_{mn} P_{G_n}$

$B_{mn} = B_{nm}$ and can be expanded for a two plant system as

$$P_L = B_{11} P_{G1}^2 + 2 B_{12} P_{G1} P_{G2} + B_{22} P_{G2}^2$$

2.7 HYDROTHERMAL SCHEDULING LONG AND SHORT TERMS-

Long-Range Hydro-Scheduling:

The long-range hydro-scheduling problem involves the long-range forecasting of water availability and the scheduling of reservoir water releases (i.e., “drawdown”) for an interval of time that depends on the reservoir capacities. Typical long-range scheduling goes anywhere from 1 wk to 1 yr or several years. For hydro schemes with a capacity of impounding water over several seasons, the long-range problem involves meteorological and statistical analyses.

Short-Range Hydro-Scheduling

Short-range hydro-scheduling (1 day to 1 wk) involves the hour-by-hour scheduling of all generation on a system to achieve minimum production cost for the given time period. In such a scheduling problem, the load, hydraulic inflows, and unit availabilities are assumed known. A set of starting conditions (e.g., reservoir levels) is given, and the optimal hourly schedule that minimizes a desired objective, while meeting hydraulic, steam, and electric system constraints, is sought.

Hydrothermal systems where the hydroelectric system is by far the largest component may be scheduled by economically scheduling the system to produce the minimum cost for the thermal system. The schedules are usually developed to minimize thermal generation production costs, recognizing all the diverse hydraulic constraints that may exist.

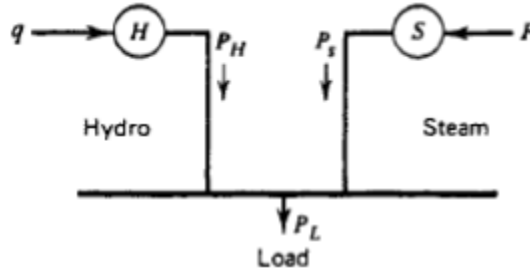

The hydroplant can supply the load by itself for a limited time. That is, for any time period j ,

$$P_{Hj}^{\max} \geq P_{\text{load } j} \quad j = 1, \dots, j_{\max}$$

The energy available from the hydroplant is insufficient to meet the load.

$$\sum_{j=1}^{j_{\max}} P_{Hj} n_j \leq \sum_{j=1}^{j_{\max}} P_{\text{load } j} n_j \quad n_j = \text{number of hours in period } j$$

$$\sum_{j=1}^{j_{\max}} n_j = T_{\max} = \text{total interval}$$

steam-plant energy required is

$$\sum_{j=1}^{j_{\max}} P_{\text{load } j} n_j - \sum_{j=1}^{j_{\max}} P_{Hj} n_j = E$$

Load Hydro Steam
energy energy energy

$$\sum_{j=1}^{N_s} P_{Sj} n_j = E \quad N_s = \text{number of periods the steam plant is run}$$

$$\sum_{j=1}^{N_s} n_j \leq T_{\max}$$

So the scheduling problem and the constraint are

$$\text{Min } F_T = \sum_{j=1}^{N_s} F(P_{Sj}) n_j$$

$$\text{subject to } \sum_{j=1}^{N_s} P_{Sj} n_j - E = 0$$

Lagrange function is
$$L = \sum_{j=1}^{N_s} F(P_{Sj}) n_j + \alpha \left(E - \sum_{j=1}^{N_s} P_{Sj} n_j \right)$$

$$\frac{\partial L}{\partial P_{Sj}} = \frac{dF(P_{Sj})}{dP_{Sj}} - \alpha = 0 \quad \text{for } j = 1, \dots, N_s$$

$$\frac{dF(P_{sj})}{dP_{sj}} = \alpha \quad \text{for } j = 1, \dots, N_s$$

So steam plant should be run at constant incremental cost for the entire period it is on. Let this optimum value of steam-generated power be P_s^* , which is the same for all time intervals the steam unit is on.

The total cost over the interval is

$$F_T = \sum_{j=1}^{N_s} F(P_s^*) n_j = F(P_s^*) \sum_{j=1}^{N_s} n_j = F(P_s^*) T_s$$

$$T_s = \sum_{j=1}^{N_s} n_j = \text{the total run time for the steam plant}$$

Suppose the steam plant cost is $F(P_s) = A + BP_s + CP_s^2$

then F_T (total cost) is $F_T = (A + BP_s^* + CP_s^{*2}) T_s$

$$\text{also } \sum_{j=1}^{N_s} P_{sj} n_j = \sum_{j=1}^{N_s} P_s^* n_j = P_s^* T_s = E$$

$$\text{so we have } T_s = \frac{E}{P_s^*}$$

$$F_T = (A + BP_s^* + CP_s^{*2}) \left(\frac{E}{P_s^*} \right)$$

$$\text{Minimizing } F_T \quad \frac{dF_T}{dP_s^*} = \frac{-AE}{P_s^{*2}} + CE = 0$$

$$\text{so } P_s^* = \sqrt{\frac{A}{C}}$$

So the unit should be operated at its maximum efficiency point (P_s^*) long enough to supply the energy needed, E. Optimal hydrothermal schedule is as shown below:

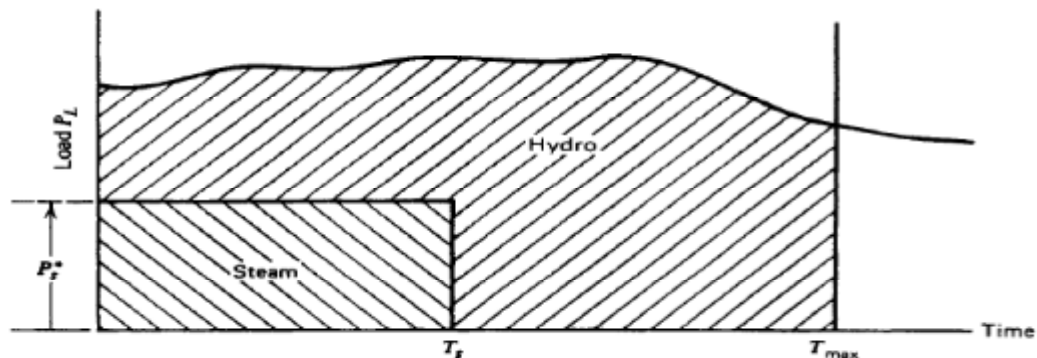

2.8 OPTIMAL POWER FLOW PROBLEM:

Basic approach to the solution of this problem is to incorporate the power flow equations as essential constraints in the formal establishment of the optimization problem. This general approach is known as the optimal power flow. Another approach is by using loss-formula method. Different techniques are:

- 1) The lambda-iteration method
- 2) Gradient methods of economic dispatch
- 3) Newton's method
- 4) Economic dispatch with piecewise linear cost functions
- 5) Economic dispatch using dynamic programming

UNIT-III

3.1 CONCEPT OF LOAD FREQUENCY CONTROL—

Frequency all over a synchronous power grid is the same in steady state. Maintaining a near-constant frequency (one may allow frequency to vary over a very narrow band) is considered an important requirement of power system operation. Frequency in a power system is intimately

related to the electrical speed of synchronous generators. The difference between mechanical and electrical torques govern acceleration of a rotor of a generator. Therefore to maintain a constant speed, mechanical input and electrical output power need to be continually matched. Electrical load can vary randomly, but the total load versus time roughly follows a trend. Modern day power systems are divided into various areas. For example in India, there are five regional grids, e.g., Eastern Region, Western Region etc. Each of these areas is generally interconnected to its neighboring areas. The transmission lines that connect an area to its neighboring area are called tie-lines. Power sharing between two areas occurs through these tie-lines. Load frequency control, as the name signifies, regulates the power flow between different areas while holding the frequency constant.

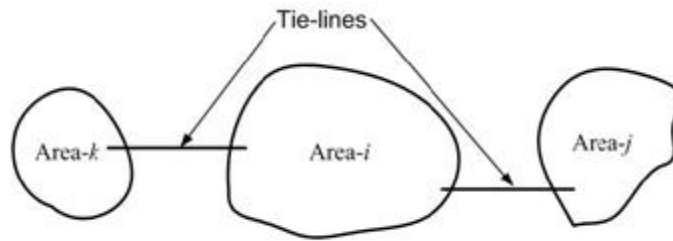

Interconnected areas in a power system.

We can therefore state that the load frequency control (LFC) has the following two objectives:

- Hold the frequency constant ($\Delta f = 0$) against any load change. Each area must contribute to absorb any load change such that frequency does not deviate.
- Each area must maintain the tie-line power flow to its pre-specified value.

The first step in the LFC is to form the **area control error (ACE)** that is defined as;

$$ACE = (P_{tie} - P_{sch}) + B_f \Delta f = \Delta P_{tie} + B_f \Delta f \text{ -----(1)}$$

where P_{tie} and P_{sch} are **tie-line power** and **scheduled power** through tie-line respectively and the constant B_f is called the **frequency bias constant**. The change in the reference of the power setting $\Delta P_{ref, i}$, of the area- i is then obtained by the feedback of the ACE through an integral controller of the form;

$$\Delta P_{ref, i} = -K_i \int ACE dt \text{ -----(2)}$$

where K_i is the integral gain. The ACE is negative if the net power flow out of an area is low or if the frequency has dropped or both. In this case the generation must be increased. This can be achieved by increasing $\Delta P_{ref, i}$. This negative sign accounts for this inverse relation between $\Delta P_{ref, i}$ and ACE. The tie-line power flow and frequency of each area are monitored in its

control center. Once the ACE is computed and $\Delta P_{ref, i}$ is obtained from eq. 2, commands are given to various turbine-generator controls to adjust their reference power settings.

3.2 LOAD FREQUENCY CONTROL OF SINGLE AREA SYSTEM-

Load frequency control deals with the control mechanism needed to maintain the system frequency. The topic of maintaining the system frequency constant is commonly known as AUTOMATIC LOAD FREQUENCY CONTROL (ALFC). It has got other nomenclatures such as Load Frequency Control, Power Frequency Control, Real Power Frequency Control and Automatic Generation Control.

The basic role of ALFC is:

- To maintain the desired megawatt output power of a generator matching with the changing load.
- To assist in controlling the frequency of larger interconnection.
- To keep the net interchange power between pool members, at the predetermined values.

The ALFC loop will maintain control only during small and slow changes in load and frequency. It will not provide adequate control during emergency situation when large megawatt imbalances occur. We shall first study ALFC as it applies to a single generator supplying power to a local service area. The real power control mechanism of a generator is shown in above Fig. The main parts are:

- 1) Speed changer
- 2) Speed governor
- 3) Hydraulic amplifier
- 4) Control valve

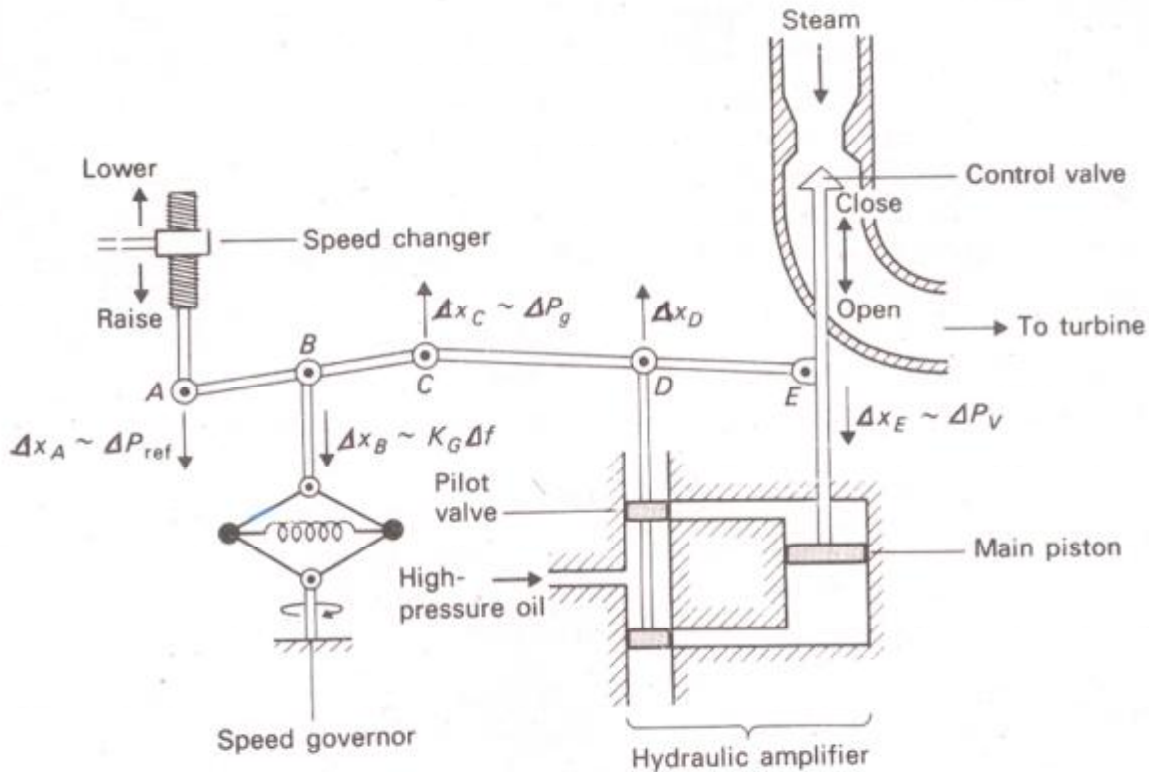

They are connected by linkage mechanism. Their incremental movements are in vertical direction. In reality these movements are measured in millimeters; but in our analysis we shall rather express them as power increments expressed in MW or p.u. MW as the case may be. The movements are assumed positive in the directions of arrows.

Corresponding to “raise” command, linkage movements will be:

“A” moves downwards;

“C” moves upwards;

“D” moves upwards;

“E” moves downwards.

This allows more steam or water flow into the turbine resulting incremental increase in generator output power. When the speed drops, linkage point “B” moves upwards and again generator output power will increase.

3.2.1 Speed Governor

The output command of speed governor is ΔP_g which corresponds to movement Δx_C . The speed governor has two inputs:

- 1) Change in the reference power setting, ΔP_{ref}

2) Change in the speed of the generator, Δf , as measured by Δx_B .

It is to be noted that a positive ΔP_{ref} will result in positive ΔP_g . A positive Δf will result in linkage points B and C to come down causing negative ΔP_g .

$$\text{Thus } \Delta P_g = \Delta P_{ref} - \Delta f/R \quad (1)$$

Here the constant R has dimension hertz per MW and is referred as speed regulation of the governor. Taking Laplace transform of eq. 1 yields

$$\Delta P_g(s) = \Delta P_{ref}(s) - \Delta f(s)/R \quad (2)$$

The block diagram corresponding to the above equation is shown in Fig. .

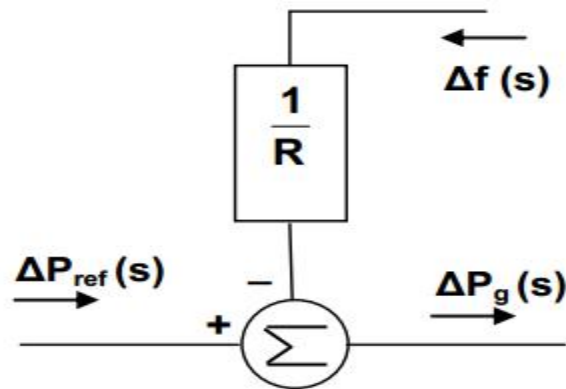

Block diagram of speed governor

Hydraulic Valve Actuator

The output of the hydraulic actuator is ΔP_v . This depends on the position of main piston, which in turn depends on the quantity of oil flow in the piston. For a small change Δx_D in the pilot valve position, we have

$$\Delta P_v = k_H \int \Delta x_D dt \quad (3)$$

The constant “ k_H ” depends on the orifice, cylinder geometries and fluid pressure. The input to Δx_D are ΔP_g and ΔP_v . It is to be noted that for a positive ΔP_g , the change Δx_D is positive. Further, for a positive ΔP_v , more fuel is admitted, speed increases, linkage point B moves downwards causing linkage points C and D to move downwards resulting the change Δx_D as negative. Thus

$$\Delta x_D = \Delta P_g - \Delta P_v \quad (4)$$

Laplace transformation of the last two equations are:

$$\Delta P_v(s) = k_H \Delta x_D(s)/s$$

$$\Delta x_D(s) = \Delta P_g(s) - \Delta P_v(s)$$

Eliminating Δx_D and writing $\Delta P_v(s)$ in terms of $\Delta P_g(s)$, we get

$$\Delta P_v(s) = \Delta P_g(s) \times 1/1 + s T_H \quad (5)$$

where T_H is the hydraulic time constant given by;

$$T_H = 1/k_H \quad (6)$$

In terms of the hydraulic valve actuator's transfer function $G_H(s)$, eq. 5 can be written as;

$$G_H(s) = \Delta P_y(s)/\Delta P_g(s) = 1/1 + s T_H \quad (7)$$

Hydraulic time constant T_H typically assumes values around 0.1 sec. The block diagram of the speed governor together with the hydraulic valve actuator is shown in Fig.

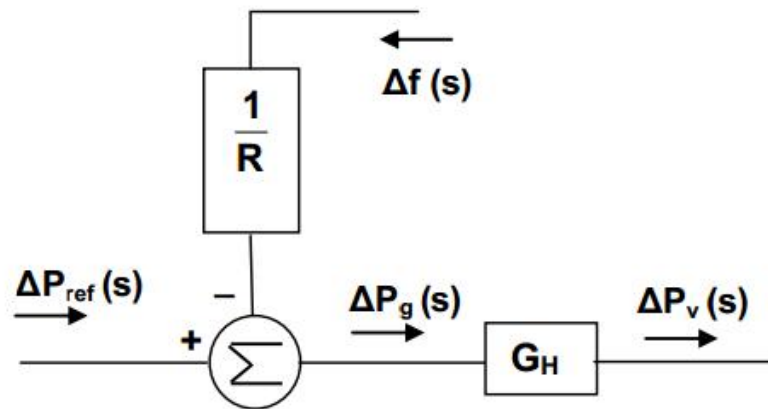

Block diagram of speed governor together with hydraulic valve actuator

3.2.2 BLOCK DIAGRAM REPRESENTATION OF SINGLE AREA SYSTEM

In normal steady state, the turbine power P_T keeps balance with the electromechanical air-gap power P_G resulting in zero acceleration and a constant speed and frequency. During transient state, let the change in turbine power be ΔP_T and the corresponding change in generator power be ΔP_G .

The accelerating power in turbine generator unit = $\Delta P_T - \Delta P_G$

$$\text{Thus accelerating power} = \Delta P_T(s) - \Delta P_G(s) \quad (8)$$

If $\Delta P_T - \Delta P_G$ is negative, it will decelerate.

The turbine power increment ΔP_T depends entirely upon the valve power increment ΔP_v and the characteristic of the turbine. Different type of turbines will have different characteristics. Taking transfer function with single time constant for the turbine, we can write

$$\Delta P_T(s) = G_T \Delta P_v(s) = \Delta P_v(s) \times 1/1 + s T_T \quad (9)$$

The generator power increment ΔP_G depends entirely upon the change ΔP_D in the load PD being fed from the generator. The generator always adjusts its output so as to meet the demand changes ΔP_D . These adjustments are essentially instantaneous, certainly in comparison with the slow changes in PT. We can therefore set

$$\Delta P_G = \Delta P_D \text{ i.e. } \Delta P_G(s) = \Delta P_D(s) \quad (10)$$

In view of equations 8,9 and 10,

$$\text{Accelerating power} = \Delta P_T(s) - \Delta P_G(s) \quad (8)$$

$$\Delta P_T(s) = G_T \Delta P_v(s) = \Delta P_v(s) \times 1/1 + s T_T \quad (9)$$

$$\Delta P_G(s) = \Delta P_D(s) \quad (10)$$

The block diagram developed is updated as shown in Fig. This corresponds to the linear model of primary ALFC loop excluding the power system response;

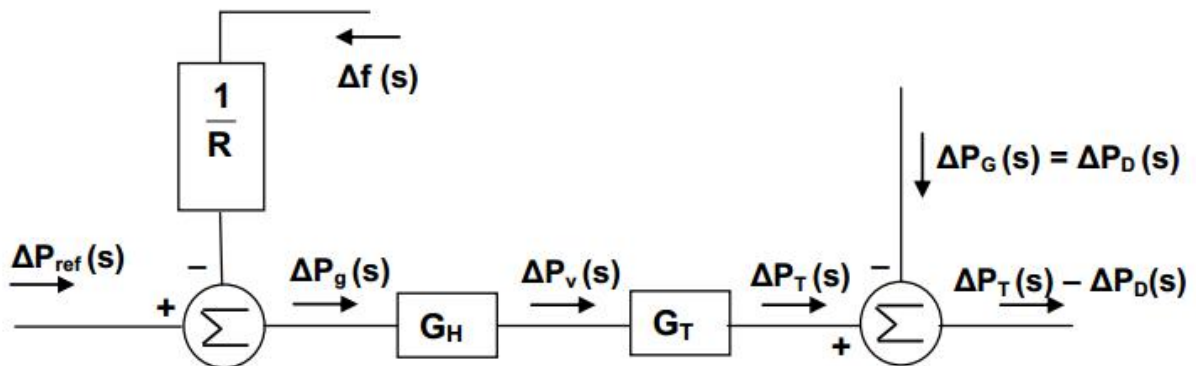

Block diagram corresponding to primary loop of ALFC excluding power system response

3.2.3 STATIC PERFORMANCE OF SPEED GOVERNOR

The present control loop shown in Fig. 4 is open. We can nevertheless obtain some interesting information about the static performance of the speed governor. The relationship between the static signals (subscript "0") is obtained by letting $s \rightarrow 0$. As $G_H(0) = G_T(0) = 1$ we obtain directly from Fig.

$$\Delta P_{T0} = \Delta P_{ref0} - \Delta f_0/R \quad (11)$$

Note that at steady state, ΔP_T is equal to ΔP_G . i.e. $\Delta P_{T0} = \Delta P_{G0}$

We consider the following three cases.

$$\Delta P_{T0} = \Delta P_{ref0} - \Delta f_0/R$$

Case A

The generator is synchronized to a network of very large size, so large in fact, that its frequency will be essentially independent of any changes in the power output of this individual generator ("infinite" network). Since $\Delta f_0 = 0$, the above eq. becomes

$$\Delta P_{T0} = \Delta P_{ref0} \quad (12)$$

Thus for a generator operating at constant speed, (or frequency) there exists a direct proportionality between turbine power and reference power setting.

Case B

Now we consider the network as "finite". i.e. its frequency is variable. We do, however, keep the speed changer at constant setting. i.e. $\Delta P_{ref} = 0$.

From eq. (11)

$$\Delta P_{T0} = \Delta P_{ref0} - \Delta f_0/R \quad (11)$$

we obtain

$$\Delta P_{T0} = - \Delta f_0/R \quad (13)$$

The above eq. shows that for a constant speed changer setting, the static increase in turbine power output is directly proportional to the static frequency drop.

DYNAMIC RESPONSE --

$$\Delta f(s) = - \frac{G_p}{1 + \frac{1}{R} G_H G_T G_p} \Delta P_D(s)$$

Finding the dynamic response, for a step load, is quite straight forward. Eq. upon inverse Laplace transformation yields an expression for $\Delta f(t)$. However, as G_H , G_T and G_p contain at least one time constant each, the denominator will be a third order polynomial resulting in unwieldy algebra.

We can simplify the analysis considerably by making the reasonable assumption that the action of speed governor plus the turbine generator is “instantaneous” compared with the rest of the power system. The latter, as demonstrated in Example has a time constant of 20 sec, and since the other two time constants are of the order of 1 sec, we will perform an approximate analysis by setting $T_H = T_T = 0$.

From eq.
$$\Delta f(s) = - \frac{G_p}{1 + \frac{1}{R} G_H G_T G_p} \Delta P_D(s) \quad \text{we get}$$

$$\Delta f(s) \approx - \frac{\frac{K_p}{1 + sT_p} \frac{M}{s}}{1 + \frac{1}{R} \frac{K_p}{1 + sT_p}} = - \frac{RK_p}{R(1 + sT_p) + K_p} \frac{M}{s}$$

Dividing numerator and denominator by $R T_p$ we get

$$\Delta f(s) \approx - \frac{\frac{K_p}{1 + sT_p} \frac{M}{s}}{1 + \frac{1}{R} \frac{K_p}{1 + sT_p}} = - \frac{RK_p}{R(1 + sT_p) + K_p} \frac{M}{s}$$

$$\Delta f(s) = - \frac{K_p}{T_p} M \frac{1}{s(s + \frac{R + K_p}{RT_p})}$$

Using the fact

$$\frac{A}{s(s + \alpha)} = \frac{A}{\alpha} \left[\frac{1}{s} - \frac{1}{s + \alpha} \right] \text{ and noting } \frac{A}{\alpha} = -M \frac{K_p}{T_p} \frac{RT_p}{R + K_p} = -M \frac{RK_p}{R + K_p}$$

$$\Delta f(s) = - M \frac{R K_p}{R + K_p} \left[\frac{1}{s} - \frac{1}{s + \frac{R + K_p}{R T_p}} \right]$$

Making use of previous numerical values: $M = 0.01$ p.u. MW; $R = 2.0$ Hz / p.u. MW; $K_p = 100$ Hz / p.u. MW; $T_p = 20$ sec.

$$M \frac{R K_p}{R + K_p} = \frac{2}{102} = 0.01961; \quad \frac{R + K_p}{R T_p} = \frac{102}{40} = 2.55$$

The approximate time response is purely exponential and is given by

$$\Delta f(t) = - 0.01961 (1 - e^{-2.55 t}) \text{ Hz}$$

Fig. shows this response. For comparison, the response with the inclusion of the time constants T_G and T_T is also shown. It is to be observed that the primary loop of ALFC does not give the desired objective of maintaining the frequency constant. We need to do something more to bring the frequency error to zero. Before discussing the necessary control which can make the frequency error to zero, we shall shed some light on to the physical mechanism in the primary loop of ALFC.

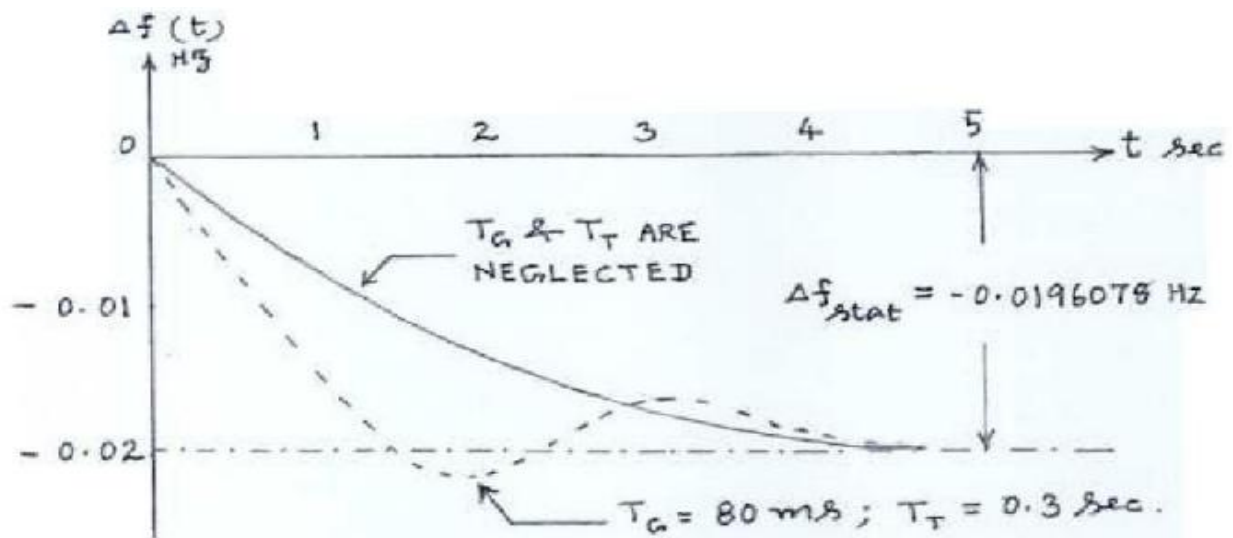

Dynamic Response

3.2.4 PROPORTIONAL PLUS INTEGRAL CONTROL-

It is seen from the previous discussion that with the speed governing system installed in each area, for a given speed changer setting, there is considerable frequency drop for increased system load. In the example seen, the frequency drop is 0.01961 Hz for 20 MW. Then the steady state drop in frequency from no load to full load (2000 MW) will be 1.961 Hz. System frequency specification is rather stringent and therefore, so much change in frequency cannot be tolerated. In fact, it is expected that the steady state frequency change must be zero. In order to maintain the frequency at the scheduled value, the speed changer setting must be adjusted automatically by monitoring the frequency changes.

For this purpose, INTEGRAL CONTROLLER is included. In the integral controller the frequency error is first amplified and then integrated. Further, a negative polarity is also included so that a NEGATIVE frequency deviation will give rise to RAISE command. The signal fed into the integrator is referred as Area Controlled Error (ACE) = Δf . Thus

$$\Delta P_{ref} = - K_i \int \Delta f \, dt$$

Taking Laplace transformation

$$\Delta P_{ref}(s) = - \frac{K_i}{s} \Delta F(s)$$

The gain constant K_i controls the rate of integration and thus the speed of response of the loop.

$$\Delta P_{ref}(s) = - \frac{K_i}{s} \Delta F(s)$$

For this signal $\Delta f(s)$ is fed to an integrator whose output controls the speed changer position resulting in the block diagram configuration shown in Fig. below.

As long as an error remains, the integrator output will increase, causing the speed changer to move. When the frequency error has been reduced to zero, the integrator output ceases and the speed changer position attains a constant value. Integral controller will give rise to ZERO STEADY STATE FREQUENCY ERROR following a step load change because of the reason stated above.

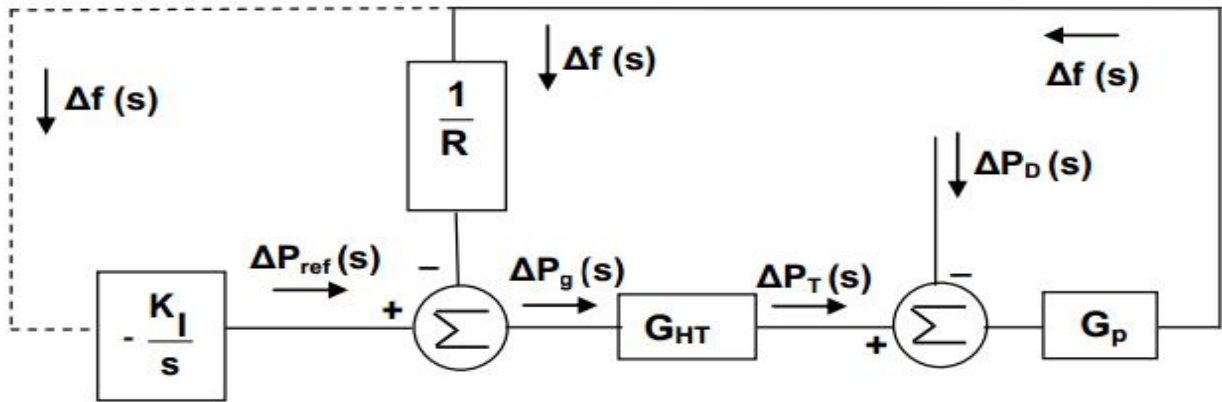

Block diagram corresponding to complete ALFC

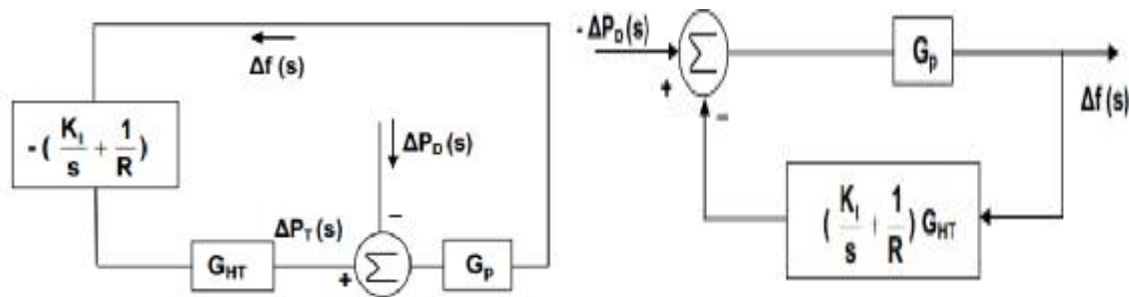

Reduced block diagram

Therefore;

$$\Delta f(s) = - \frac{G_p}{1 + \frac{K_I}{s} G_{HT} G_p + \frac{1}{R} G_{HT} G_p} \Delta P_D(s)$$

3.2.5 LOAD FREQUENCY CONTROL AND ECONOMIC DISPATCH CONTROL

Economic dispatch control determines the power output of each power plant, and power output of each generating unit within a power plant, which will minimize the overall cost of fuel needed to serve the system load.

- We study first the most economical distribution of the output of a power plant between the generating units in that plant. The method we develop also applies to economic

scheduling of plant outputs for a given system load without considering the transmission loss.

- Next, we express the transmission loss as a function of output of the various plants.
- Then, we determine how the output of each of the plants of a system is scheduled to achieve the total cost of generation minimum, simultaneously meeting the system load plus transmission loss

Both the load frequency control and the economic dispatch issue commands to change the power setting of each turbine-governor unit. At a first glance it may seem that these two commands can be conflicting. This however is not true. A typical automatic generation control strategy is shown in Fig. in which both the objective are coordinated. First we compute the area control error. A share of this ACE, proportional to α_i , is allocated to each of the turbine-generator unit of an area. Also the share of unit- i , $\gamma_i \times \Sigma(P_{DK} - P_k)$, for the deviation of total generation from actual generation is computed. Also the error between the economic power setting and actual power setting of unit- i is computed. All these signals are then combined and passed through a proportional gain K_i to obtain the turbine-governor control signal.

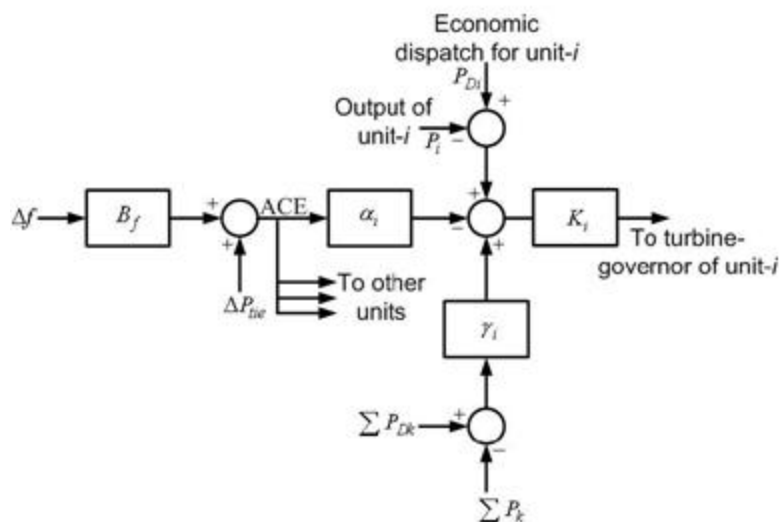

i Automatic generation control of unit-i.

3.3. TWO AREA CONTROL-

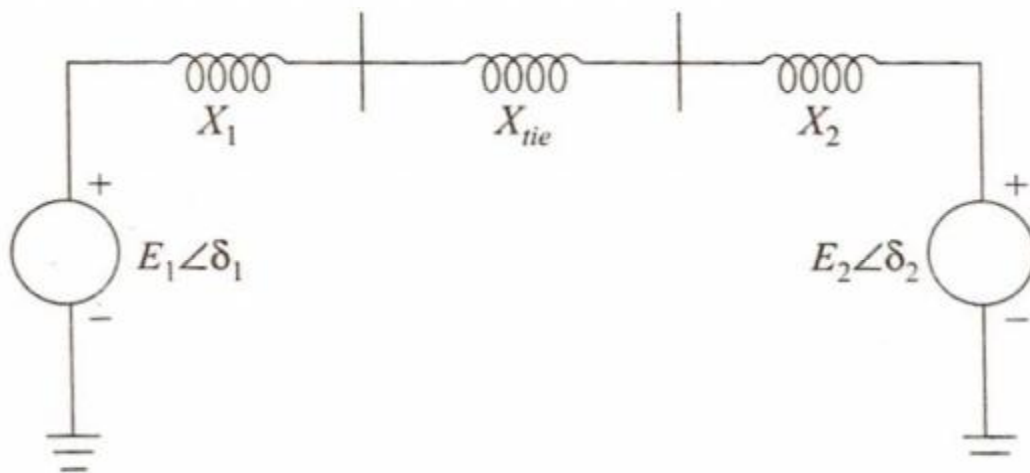
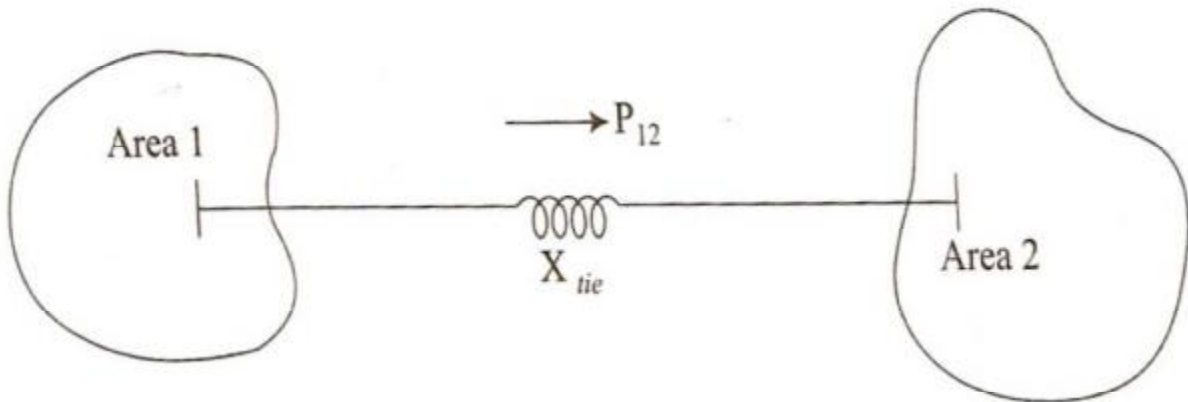

Two area control

Under steady state the power transferred over the tie-line is given by

$$P_{12} = \frac{|E_1||E_2|\sin\delta_{12}}{X_{12}}$$

Where $X_{12} = X_1 + X_{tie} + X_2$ and $\delta_{12} = \delta_1 - \delta_2$. For a small deviation ΔP_{12} of the tie line power flow,

$$\Delta P_{12} = \frac{\partial P_{12}}{\partial \delta_{12}} \Big|_{\delta_{12}} \Delta \delta_{12} = P_S \Delta \delta_{12}$$

where $\left. \frac{\partial P_{12}}{\partial \delta_{12}} \right|_{\delta_{12}} = P_S$ is the slope of the power angle curve evaluated at the initial operating point and is the synchronizing power coefficient.

$$P_S = \left. \frac{\partial P_{12}}{\partial \delta_{12}} \right|_{\delta_{12}} = \frac{|E_1| |E_2| \cos \delta_{12}}{X_{12}}$$

A positive ΔP_{12} occurs when $\Delta \delta_1 > \Delta \delta_2$ and indicates a flow of real power from area 1 to area 2. This has the effect of increasing load on area 1 and decreasing load on area 2. Hence ΔP_{12} has negative sign for area 1 and positive sign for area 2.

Tie–line bias control:

If the areas are equipped only with primary control of the ALFC, a change in load in one area met is with change in generation in both areas, change in tie–line power and a change in the frequency. Hence, a supplementary control is necessary to maintain

Frequency at the nominal value

Maintain net interchange power with other areas at the scheduled values

Let each area absorb its own load

Hence, the supplementary control should act only for the areas where there is a change in load. To achieve this, the control signal should be made up of the tie–line flow deviation plus a signal proportional to the frequency deviation. A suitable proportional weight for the frequency deviation is the frequency – response characteristic β . This is the reason why β is also called the frequency bias factor. This control signal is called the area control error (ACE). In a two area system

$$\begin{aligned} ACE_1 &= \Delta P_{12} + B_1 \Delta f; & B_1 &= \beta_1 \\ ACE_2 &= \Delta P_{21} + B_2 \Delta f; & B_2 &= \beta_2 \end{aligned}$$

The ACE represents the required change in area generation and its unit is MW. ACEs are used as control signals to activate changes in the reference set points. Under steady state ΔP_{12} and Δf will be zero. An increase in load of area 1, which leads to a decrease in system frequency. The primary ALFC loop limits the frequency deviation to

$$\Delta f = \frac{-\Delta P_{L1}}{\beta_1 + \beta_2}$$

The tie–line power has a deviation $\Delta P_{12} = \beta_2 \Delta f$. Supplementary control of area 1 responds to ΔP_{L1} and the generation changed so that ACE becomes zero.

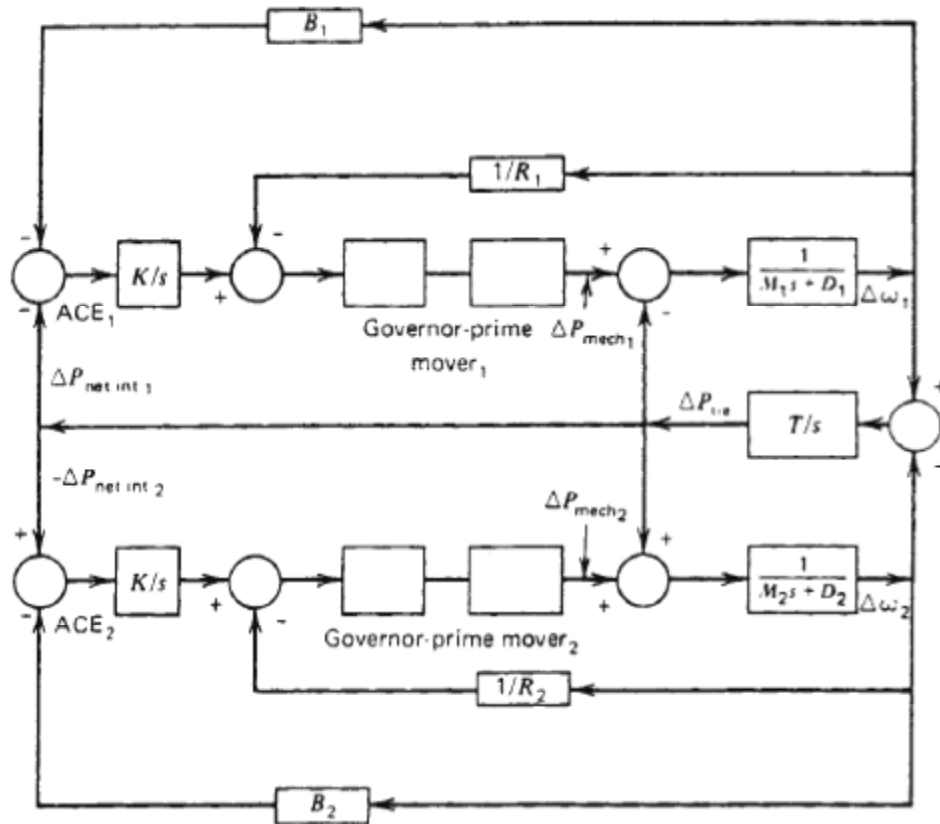

Block diagram of two area system with supplementary control

UNIT-IV

4.1 AUTOMATIC VOLTAGE CONTROL -

4.1. 1 Schematic diagram and block diagram representation

The voltage of the generator is proportional to the speed and excitation (flux) of the generator. The speed being constant, the excitation is used to control the voltage. Therefore, the voltage control system is also called as excitation control system or automatic voltage regulator (AVR). For the alternators, the excitation is provided by a device (another machine or a static device) called exciter. For a large alternator the exciter may be required to supply a field current of as large as 6500A at 500V and hence the exciter is a fairly large machine. Depending on the way the dc supply is given to the field winding of the alternator (which is on the rotor), the exciters are classified as: i) DC Exciters; ii) AC Exciters; and iii) Static Exciters.

Accordingly, several standard block diagrams are developed by the IEEE working group to represent the excitation system. A schematic of an excitation control system is shown in Fig2.1.

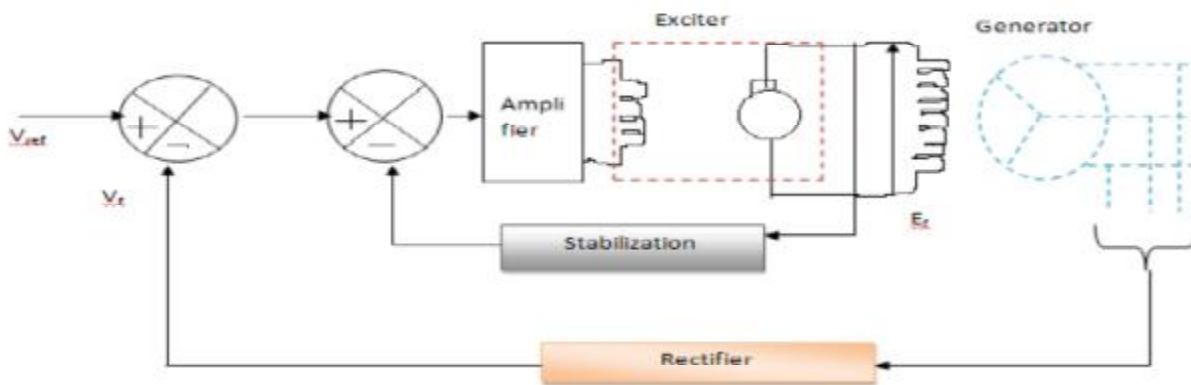

A schematic of excitation (voltage) control system

A simplified block diagram of the generator voltage control system is shown in Fig.

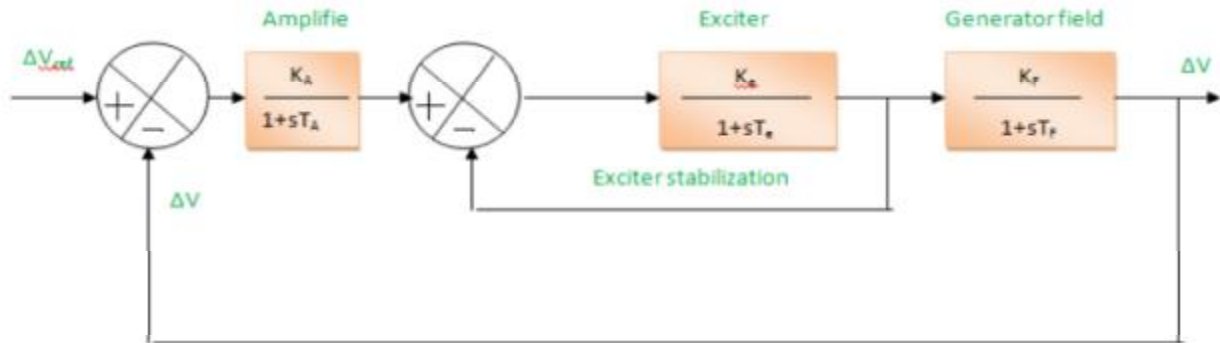

A simplified block diagram of voltage (excitation) control system

The generator terminal voltage V_t is compared with a voltage reference V_{ref} to obtain a voltage error signal ΔV . This signal is applied to the voltage regulator shown as a block with transfer function $K_A/(1+T_{As})$. The output of the regulator is then applied to exciter shown with a block of transfer function $K_e/(1+T_{es})$. The output of the exciter E_{fd} is then applied to the field winding which adjusts the generator terminal voltage. The generator field can be represented by a block with a transfer function $K_F/(1+sT_F)$.

The total transfer function is
$$\frac{\Delta V}{\Delta V_{ref}} = \frac{G(s)}{1 + G(s)}$$

4.1.2 DIFFERENT TYPES OF EXCITATION SYSTEMS & THEIR CONTROLLERS-

The basic function of an excitation system is to provide necessary direct current to the field winding of the synchronous generator. The excitation system must be able to automatically adjust the field current to maintain the required terminal voltage. The DC field current is obtained from a separate source called an exciter. The excitation systems have taken many forms over the years of their evolution. The following are the different types of excitation systems.

- a. DC excitation systems
- b. AC excitation systems
- c. Brushless AC excitation systems
- d. Static excitation systems

DC Excitation Systems----

In DC excitation system, the field of the main synchronous generator is fed from a DC generator, called exciter. Since the field of the synchronous generator is in the rotor, the required field current is supplied to it through slip rings and brushes. The DC generator is driven from the same turbine shaft as the generator itself. One form of simple DC excitation system is shown in Fig. This type of DC excitation system has slow response. Normally for 10 MVA synchronous generator, the exciter power rating should be 20 to 35 KW for which we require huge the DC generator. For these reasons, DC excitation systems are gradually disappearing.

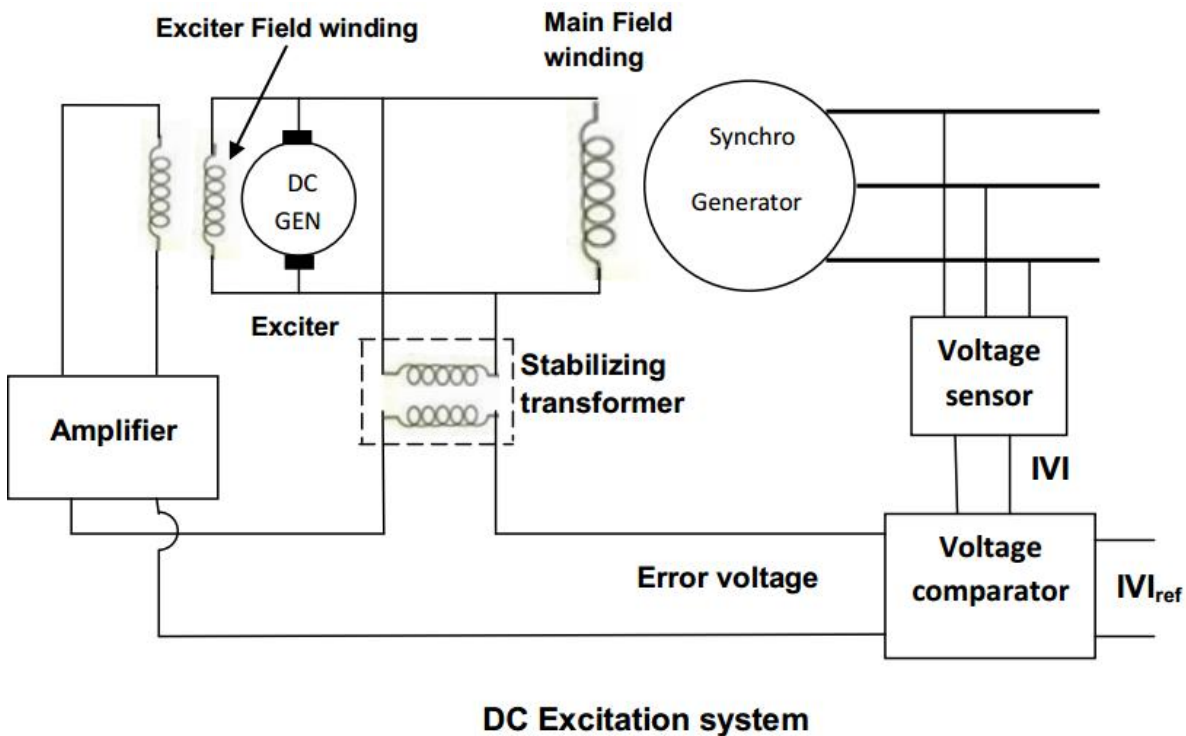

AC Excitation Systems---

In AC excitation system, the DC generator is replaced by an alternator of sufficient rating, so that it can supply the required field current to the field of the main synchronous generator. In this scheme, three phase alternator voltage is rectified and the necessary DC supply is obtained. Generally, two sets of slip rings, one to feed the rotating field of the alternator and the other to supply the rotating field of the synchronous generator, are required. Basic blocks of AC excitation system are shown in Fig.

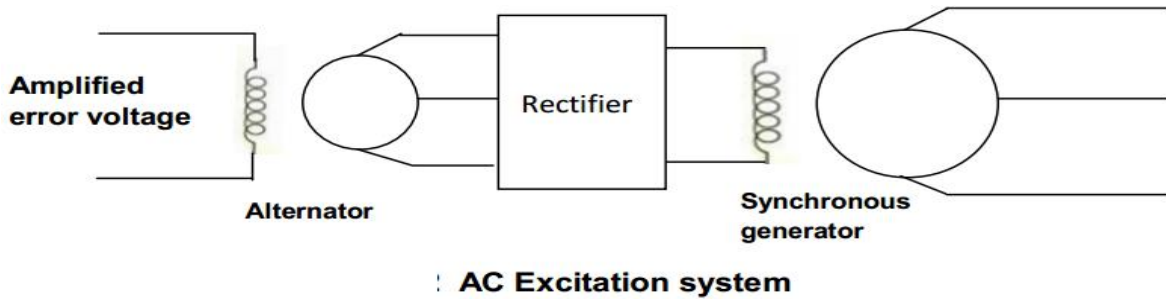

Brushless AC Excitation Systems---

Old type AC excitation system has been replaced by brushless AC excitation system wherein, inverted alternator (with field at the stator and armature at the rotor) is used as exciter. A full wave rectifier converts the exciter AC voltage to DC voltage. The armature of the exciter, the full wave rectifier and the field of the synchronous generator form the rotating components. The rotating components are mounted on a common shaft. This kind of brushless AC excitation system is shown in Fig.

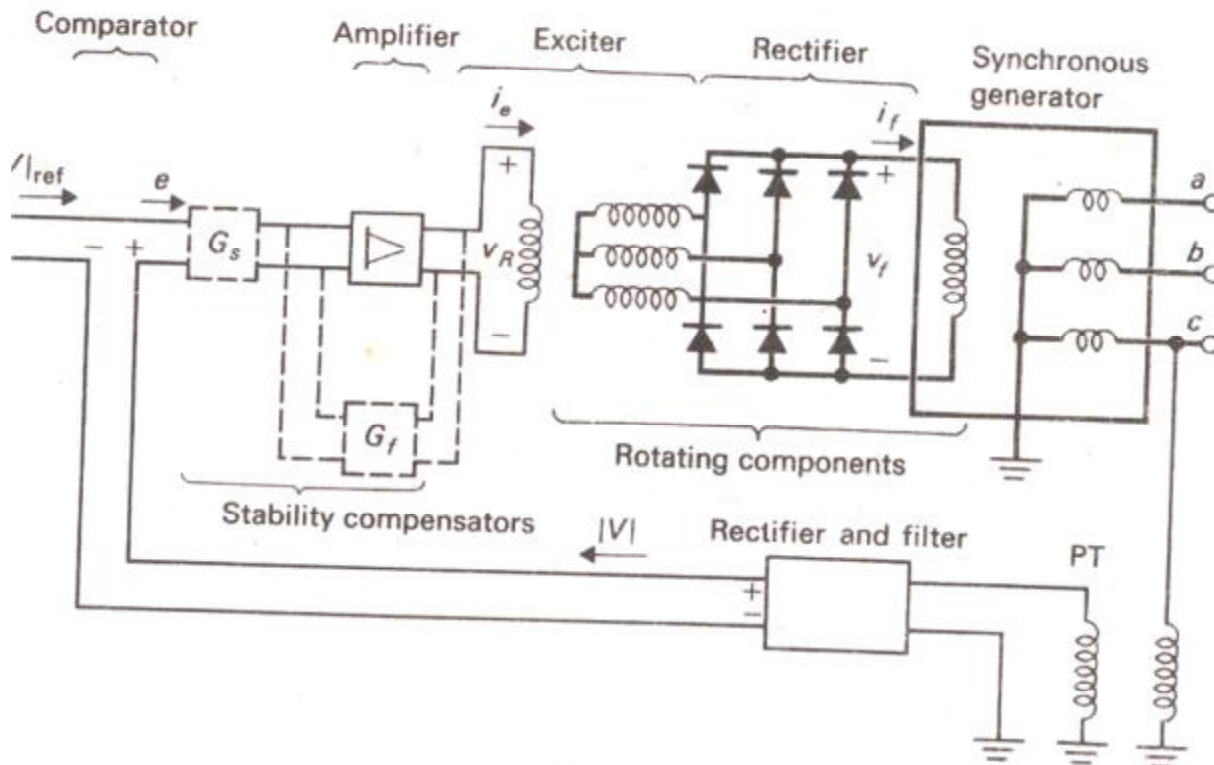

Static Excitation Systems--

In static excitation system, a portion of the AC from each phase of synchronous generator output is fed back to the field windings, as DC excitations, through a system of transformers, rectifiers, and reactors. An external source of DC is necessary for initial excitation of the field windings. On engine driven generators, the initial excitation may be obtained from the storage batteries used to start the engine.

4.2.1 CONCEPT OF VOLTAGE CONTROL-

The control of voltage and reactive power is a major issue in power system operation. This is because of the topological differences between distribution and transmission systems, different strategies have evolved. This paper contains contributions of novel reactive power control and voltage stability schemes for distribution and transmission systems. A particular interest is taken to the development of control schemes to avoid so-called voltage collapse, which can result in widespread outages. In order to achieve efficient and reliable operation of

power system, the control of voltage and reactive power should satisfy the following objectives:

- Voltages at all terminals of all equipment in the system are within acceptable limits
- System stability is enhanced to maximize utilization of the transmission system
- The reactive power flow is minimized so as to reduce RI^2 and XI^2 losses.

Almost all power transported or consumed in alternating current (AC) networks, supply or consume two of powers: real power and reactive power. Real power accomplishes useful work while reactive power supports the voltage that must be controlled for system reliability. Reactive power is essential to move active power through the transmission and distribution system to the customer. For AC systems voltage and current pulsate at the system frequency. Although AC voltage and current pulsate at same frequency, they peak at different time power is the algebraic product of voltage and current. Real power is the average of power over cycle and measured by volt-amperes or watt. The portion of power with zero average value called reactive power measured in **volt-amperes reactive or vars**.

4.2.2 VOLTAGE CONTROL USING TAP CHANGING TRANSFORMERS -

Voltage control using tap changing transformers is the basic and easiest way of controlling voltages in transmission, sub-transmission and distribution systems. In high voltage and extra-high voltage lines On Load Tap Changing (OLTC) transformers are used while ordinary off-load tap changers prevail in distribution circuits. It is to be noted that tap changing transformers do not generate reactive power. Consider the operation of transmission line with tap changing transformers at both the ends as shown in Fig..

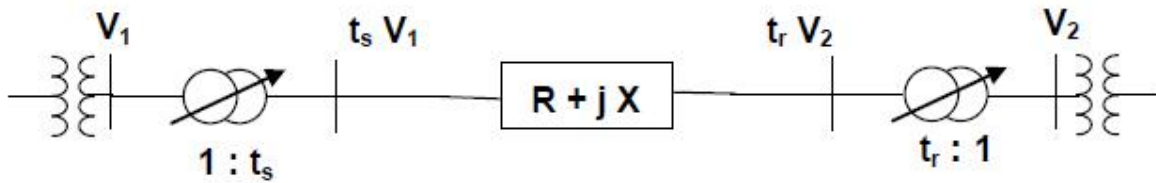

Transmission line with tap setting transformers

Let t_s and t_r be the off-nominal tap settings of the transformers at the sending end and receiving end respectively. For example, a transformer of nominal ratio 6.6 kV to 33 kV when tapped to give 6.6 kV to 36 kV, it is set to have off-nominal tap setting of $36 / 33 = 1.09$. The above transformer is equivalent to transformer with nominal ratio of 6.6 kV to 33 kV, in series with an auto transformer of ratio 33:36 i.e 1: 1.09.

In the following discussion, magnitudes of voltages are referred as V_1 and V_2 . It is to be noted that V_1 and V_2 are the nominal voltages (Transmission line voltages such as 33 kV, 66 kV, 132 kV and 400 kV) at the ends of the line and the actual voltages being $t_s V_1$ and $t_r V_2$. It is required to determine the tap changing ratios required to completely compensate for voltage drop in the line. The product $t_s t_r$ will be made unity; this ensures that the overall voltage level remains in the same order and that the minimum range of taps on both sides is used. The total impedance of line and transformers referred to high voltage side is $(R + jX) \Omega$

4.2.3 Shunt Compensation, Series compensation, Phase angle compensation/ Reactive Power Control in Electrical Systems

During the daily operation, power systems may experience both over-voltage and under-voltage violations that can be overcome by voltage/Var control. Through controlling the production, adsorption, and flow of reactive power at all levels in the system, voltage/Var control can maintain the voltage profile within acceptable limit and reduce the transmission losses. Transmission connected generators are generally required to support reactive power flow. For example, Transmission system generators are required by the Grid Code Requirements to supply their rated power between the limits of 0.85 power factor lagging and 0.90 power factor leading at the designated terminals. The system operator will perform switching actions to maintain a secure and economical voltage profile while maintaining a reactive power balance equation. For most of power circuit, resistance R will be much less as compared to reactance X . Neglecting the resistance of the transmission line, we get Voltage drop; $\Delta V = QX/V$

From eq. we can state that the voltage drop in the transmission line is directly proportional to the reactive power flow (Q-flow) in the transmission line. Most of the electric load is inductive in nature. In a day, during the peak hours, Q-flow will be heavy, resulting more voltage drop. However, during off-peak hours, the load will be very small and the distributed shunt capacitances throughout the transmission line become predominant making the receiving-end

voltage greater than the sending-end voltage (Ferranti effect). Thus during off-peak hours there may be voltage rise in the transmission line from sending-end to receiving-end. Thus the sending end will experience large voltage drop during peak load condition and even voltage rise during off-peak load condition.

Reactive power control is necessary in order to maintain the voltage drop in the transmission line within the specified limits. During peak hours, voltage drop can be reduced by decreasing the Q-flow in the transmission line. This is possible by externally injecting “a portion of load reactive power” at the receiving-end. Fig. illustrates the effect of injecting the reactive power.

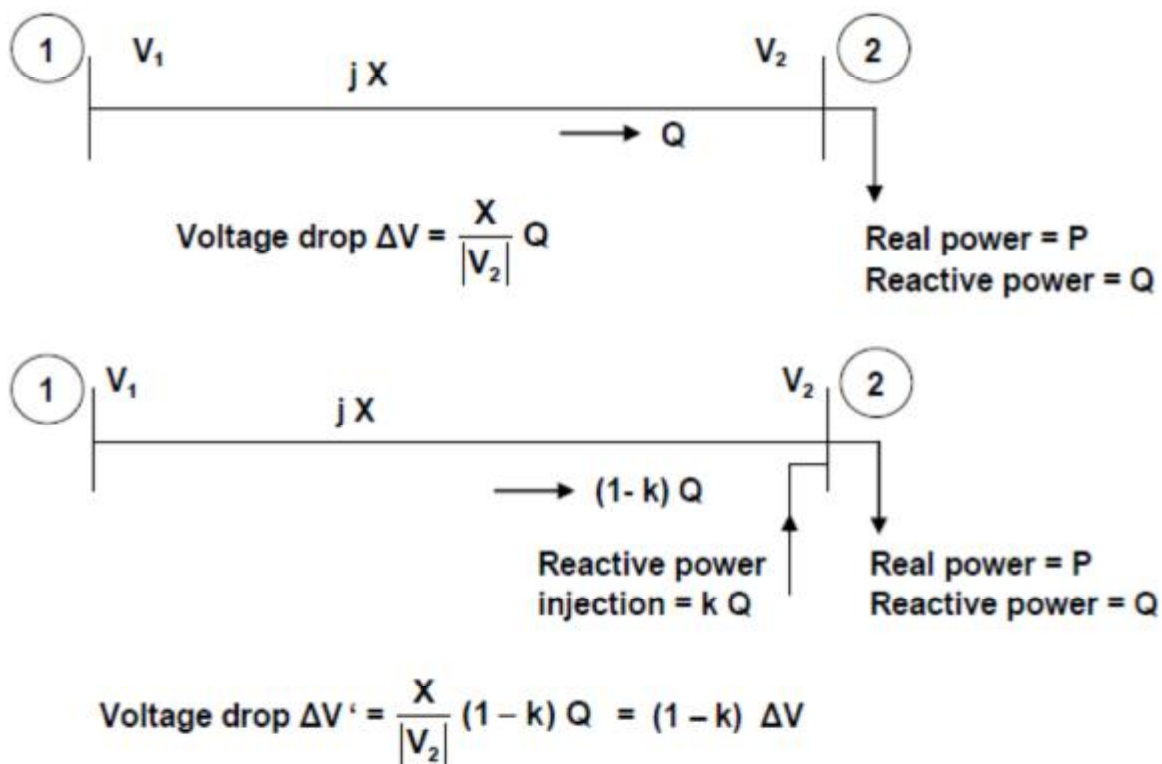

Reactive power can be injected into the power network by connecting

1. Shunt capacitors
2. Synchronous compensator (Synchronous phase modifier)
3. Static VAR compensator (SVC)

During off-peak period, “voltage rise” can be reduced by absorbing the reactive power. This is possible by connecting

1. Shunt reactor

2. Synchronous compensator (Synchronous phase modifier)
3. Static VAR compensator (SVC)

Shunt Capacitors -

Shunt capacitor are used in circuit with lagging power factors such as the one created by peak load condition. Capacitors are connected either directly to a bus bar or to the tertiary winding of a main transformer. Reactive power supplied by the capacitor is given by ;

$$Q_C = |V| |I_C| \sin 90^\circ$$

$$Q_C = |V| |I_C| = \frac{|V|^2}{X_C} = |V|^2 \omega C \text{ VAR / phase}$$

where $|V|$ is the phase voltage and C is the capacitance / phase. Unfortunately, as the voltage falls, the VARs produced by a shunt capacitor reduce. Thus when needed most, their effectiveness falls.

Shunt capacitors and reactors and series capacitors provide passive compensation. They are either permanently connected to the transmission and distribution system or switched. They contribute to voltage control by modifying the network characteristics. Synchronous condensers, SVC and STATCOM provide active compensation . The voltages of the buses to which they are connected. Together with the generating units, they establish voltages at specific points in the system. Voltages at other locations in the system are determined by active and reactive power flows through various elements, including the passive compensating devices.

The primary purposes of transmission system shunt compensation near load areas are voltage control and load stabilization. Mechanically switched shunt capacitor banks are installed at major substations in load areas for producing reactive power and keeping voltage within required limits. For voltage stability shunt capacitor banks are very useful in allowing nearby generators to operate near unity power factor. This maximizes fast acting reactive reserve. Compared to SVCs, mechanically switched capacitor banks have the advantage of much lower cost. Switching speeds can be quite fast. Current limiting reactors are used to minimize switching transients. There are several disadvantages to mechanically switched capacitors. For voltage emergencies the shortcoming of shunt capacitor banks is that the reactive power output drops with the voltage squared. For transient voltage instability the switching may not be fast enough to prevent induction motor stalling. Precise and rapid control of voltage is not possible. Like inductors, capacitor banks are discrete devices, but they are often configured with several steps to provide a limited amount of variable control. If voltage collapse results in a system, the stable parts of the system may experience damaging over voltages immediately following separation. Shunt

capacitors banks are always connected to the bus rather than to the line. They are connected either directly to the high voltage bus or to the tertiary winding of the main transformer. Shunt capacitor banks are breaker-switched either automatically by a voltage relays or manually

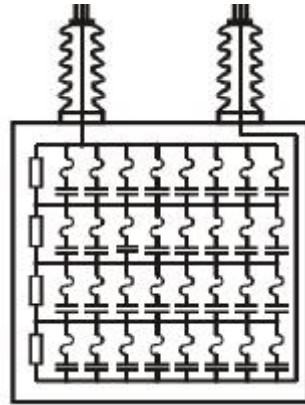

Figure :Typical capacitor bank

The primary purpose of transmission system shunt compensation near load areas is voltage control and load stabilization. In other words, shunt capacitors are used to compensate for $X I^2$ losses in transmission system and to ensure satisfactory voltage levels during heavy load conditions. Shunt capacitors are used in power system for power factor correction. The objective of power factor correction is to provide reactive power close to point.

Shunt Reactors –

Shunt reactors are used in circuit with leading power factors such as the one created by lightly loaded cables. The inductors are usually coreless type and possess linear type characteristics. If X_L is the inductive reactance per phase and $|V|$ is the phase voltage, reactive power absorbed by the inductor is given by;

$$Q_L = |V| |I_L| = \frac{|V|^2}{X_L} = \frac{|V|^2}{\omega L} \text{ VAR / phase}$$

Synchronous Compensators-

A synchronous compensator is a synchronous motor running without a mechanical load. Depending on the value of excitation, it can either inject or absorb reactive power. When used with a voltage regulator, the compensator can automatically run over-excited at times of high load and supply the required reactive power. It will be under-excited at light load to absorb the reactive power.

Static VAR Compensator—

Shunt capacitor compensation is required to enhance the system voltage during heavy load condition while shunt reactors are needed to reduce the over-voltage occurring during light load conditions. Static VAR Compensator (SVC) can perform these two tasks together utilizing the Thyristor Controlled Reactor (TCR). SVC is basically a parallel combination of controlled reactor and a fixed capacitor as shown in Fig.

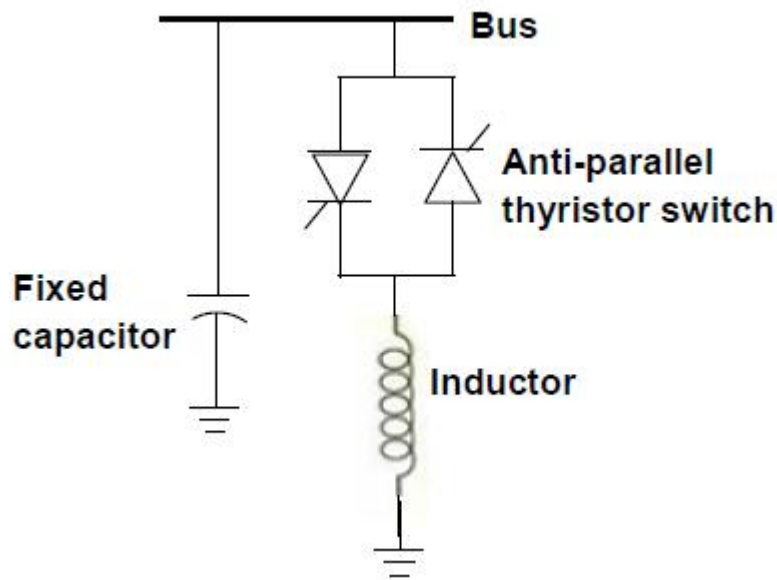

The reactor control is done by an anti-parallel thyristor switch assembly. The firing angle of the thyristors governs the voltage across the inductor, thus controlling the reactor current. Thereby the reactive power absorption by the inductor can be controlled. The capacitor, in parallel with the reactor, supplies the reactive power of Q_C VAR to the system. If Q_L is the reactive power absorbed by the reactor, the net reactive power injection to the bus becomes;

$$Q_{net} = Q_C - Q_L$$

In SVC, reactive power Q_L can be varied and thus reactive power Q_{net} is controllable. During heavy load period, Q_L is lesser than Q_C while during light load condition, Q_L is greater than Q_C . SVC has got high application in transmission bus voltage control. Being static this equipment, it is more advantageous than synchronous compensator.

UNIT-V

5.1 STATE ESTIMATION-

State estimation technique is the process of estimating a value of the system state variable, which is a phasor of the voltage magnitudes and angles at different nodes or buses of the system. Various measured quantities-power, voltage and current are analog quantities which are passed through A/D converters, and then digital outputs are telemetered to energy control center over various communication links, where these are processed to find present state of the power system. The process involves imperfect (bad) measurements and estimation process of the system states is based on a statistical method that estimates the true value of the state variables to minimize or maximize the selected criterion. Though errors (imperfect measurement) should be reduced by the state estimation, the reliability of estimated data will reduce when some bad measurements are present in the system. Available output states at energy control center are then used to find the system performance in real time for system security and conditions of economic dispatch.

The system gets information about the power system from remote terminal units (RTU) that encode measurement transducer outputs and opened/closed status information into digital signals that are transmitted to the operation control center over communication circuits. The information coming into the energy control center is broken down as breaker/switch, transformer tap status indications and analog measurements. The analog measurements of generator output must be used directly by the AGC.

Data received at energy control centers through telemetry link contain errors due to various reasons such as metering error, communication error and error due to changes in the system. Static-state estimator processes the data received and filters out the errors present in the telemetered data. For obtaining reliability in estimated system states, redundant measurements are taken i.e. the number of equations to be solved are more than the number of unknown state variables. The estimator is designed to produce the “best estimate” of the system states. Existing operating conditions of the system are determined by state estimation.

Measurement equations can be written as:

$$Z_i = h_i(x) + e_i$$

where $Z_i = i^{\text{th}}$ measurement

$x =$ state variable

$h_i(x)$ represents non linear function of measured quantity in terms of state variable. e_i represents measurement error, this is also known as Gaussian random variable noise term or bad data, with zero mean and respective variances $\sigma_1^2, \sigma_2^2, \dots$. If there are n measurements and m state variables then $m < n$, this represents redundancy in measurement, this is necessary in order to get reliable estimated system states.

Now weighted least square estimation is done in which the objective function is formed by taking weighted sum of squares of errors.

$$\text{Objective function } f = \sum_{i=1}^n \frac{e_i^2}{\sigma_i^2}$$

where σ_i^2 = error variance, $\frac{1}{\sigma_i^2} = w_i \Rightarrow$ weight

The objective function f is minimized. Assuming there are four measurements so $n=4$ and the objective function f is

$$f = \frac{\{Z_1 - h_1(x_1, x_2)\}^2}{\sigma_1^2} + \frac{\{Z_2 - h_2(x_1, x_2)\}^2}{\sigma_2^2} + \frac{\{Z_3 - h_3(x_1, x_2)\}^2}{\sigma_3^2} + \frac{\{Z_4 - h_4(x_1, x_2)\}^2}{\sigma_4^2}$$

following equation

must be satisfied for minimizing the objective function f by estimates \hat{x}_1 and \hat{x}_2 , (here by assuming two state variables and four measurements)

$$H_x^T R^{-1} \begin{bmatrix} Z_1 - h_1(\hat{x}_1, \hat{x}_2) \\ Z_2 - h_2(\hat{x}_1, \hat{x}_2) \\ Z_3 - h_3(\hat{x}_1, \hat{x}_2) \\ Z_4 - h_4(\hat{x}_1, \hat{x}_2) \end{bmatrix} = \begin{bmatrix} 0 \\ 0 \end{bmatrix} \quad \text{where } H_x = \begin{bmatrix} \frac{\partial h_1}{\partial x_1} & \frac{\partial h_1}{\partial x_2} \\ \frac{\partial h_2}{\partial x_1} & \frac{\partial h_2}{\partial x_2} \\ \frac{\partial h_3}{\partial x_1} & \frac{\partial h_3}{\partial x_2} \\ \frac{\partial h_4}{\partial x_1} & \frac{\partial h_4}{\partial x_2} \end{bmatrix} \Rightarrow \text{Jacobian Matrix}$$

$H_x^T \Rightarrow$ Transpose of H_x

$$R^{-1} = \begin{bmatrix} \frac{1}{\sigma_1^2} & 0 & 0 & 0 \\ 0 & \frac{1}{\sigma_2^2} & 0 & 0 \\ 0 & 0 & \frac{1}{\sigma_3^2} & 0 \\ 0 & 0 & 0 & \frac{1}{\sigma_4^2} \end{bmatrix}$$

$R^{-1} \Rightarrow$ weighting matrix W

To solve the above equation for state estimates \hat{x}_1 and \hat{x}_2 , same procedure is followed as in Newton-Raphson power flow, $h_1(x_1, x_2)$ is linearized about initial point $(x_1^{(0)}, x_2^{(0)})$ which gives

$$h_1(x_1, x_2) = h_1(x_1^{(0)}, x_2^{(0)}) + \Delta x_1^{(0)} \left. \frac{\partial h_1}{\partial x_1} \right|^0 + \Delta x_2^{(0)} \left. \frac{\partial h_1}{\partial x_2} \right|^0$$

where $\Delta x_i^{(0)} = x_i^{(1)} - x_i^{(0)}$ represents the typical state-variable correction and $x_i^{(1)}$ is the first calculated value of x_i . Similarly $h_2(x_1, x_2)$, $h_3(x_1, x_2)$ and $h_4(x_1, x_2)$ can be expanded. Substituting these expansions in the equation we get

$$H_x^{(0)T} R^{-1} \begin{bmatrix} Z_1 - h_1(x_1^{(0)}, x_2^{(0)}) \\ Z_2 - h_2(x_1^{(0)}, x_2^{(0)}) \\ Z_3 - h_3(x_1^{(0)}, x_2^{(0)}) \\ Z_4 - h_4(x_1^{(0)}, x_2^{(0)}) \end{bmatrix} = H_x^{(0)T} R^{-1} H_x^{(0)} \begin{bmatrix} \Delta x_1^{(0)} \\ \Delta x_2^{(0)} \end{bmatrix}$$

all quantities with superscripts (0) are computed at the initial values $x_1^{(0)}$ and $x_2^{(0)}$. Corrections Δx_1 and Δx_2 should be approx. zero to satisfy Equation, so similar calculations are continued by using $\Delta x_i^{(k)} = x_i^{(k+1)} - x_i^{(k)}$ to form more general iterative equation.

$$\begin{bmatrix} x_1^{(k+1)} \\ x_2^{(k+1)} \end{bmatrix} - \begin{bmatrix} x_1^{(k)} \\ x_2^{(k)} \end{bmatrix} = (H_x^T R^{-1} H_x)^{-1} H_x^T R^{-1} \begin{bmatrix} Z_1 - h_1(x_1^{(k)}, x_2^{(k)}) \\ Z_2 - h_2(x_1^{(k)}, x_2^{(k)}) \\ Z_3 - h_3(x_1^{(k)}, x_2^{(k)}) \\ Z_4 - h_4(x_1^{(k)}, x_2^{(k)}) \end{bmatrix}$$

at each iteration the elements of Jacobian H_x and quantities $Z_j - h_j(x_1^{(k)}, x_2^{(k)})$ are evaluated from latest available values of the state variables until two successive solutions have converged to within a specified precision index, that is, until

$$|x_i^{(k+1)} - x_i^{(k)}| < \epsilon \text{ for every } i.$$

At convergence the solution $x^{(k+1)}$ corresponds to the weighted least-squares estimates of the state variables, which is denoted by

$$\hat{x}^{(k+1)} = \hat{x} = \begin{bmatrix} \hat{x}_1 \\ \hat{x}_2 \end{bmatrix}^T$$

For detecting bad data from measurements Chi-Square test is carried out. Steps for detecting bad data are as follows:

- Get the raw measurements z_i from the system to determine the weighted least square estimates \hat{x}_i of the system states.

- Substitute the estimates \hat{x}_i in the equation $\hat{z} = H\hat{x}$ to calculate the estimated values \hat{z}_i of the measurements and hence the estimated errors $\hat{e}_i = z_i - \hat{z}_i$.
- Find the weighted sum of squares $\hat{f} = \sum_{i=1}^{N_m} \frac{e_i^2}{\sigma_i^2}$.
- For number of degrees of freedom $k=N_m-N_S$ and a specified probability α , check the inequality $\hat{f} < \chi_{k,\alpha}^2$ is satisfied. If inequality is satisfied, then the measured raw data and state estimates are accepted as being accurate. α =area under the curve to the right of $\chi_{k,\alpha}^2$
- When the requirement of last step is not satisfied then there may be presence of at least one bad measurement. In such case omit the measurement corresponding to the largest standardized error and reevaluate the state estimates along with sum of squares. If the new value of \hat{f} satisfies the Chi-Square test of inequality then the omitted measurement is identified as the bad data point.

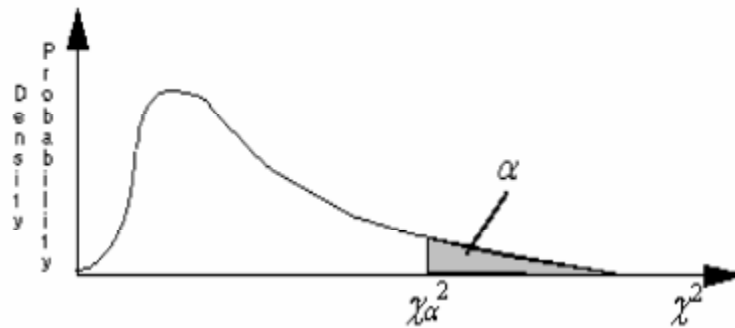

5.2 FLEXIBLE AC TRANSMISSION SYSTEMS--

5.2.1 Concept and Objectives-

The large interconnected transmission networks are susceptible to faults caused by lightning discharges and decrease in insulation clearances. The power flow in a transmission line is determined by Kirchhoff's laws for specified power injections (both active and reactive) at various nodes. While the loads in a power system vary by the time of the day in general, they are also subject to variations caused by the weather (ambient temperature) and other unpredictable factors. The generation pattern in a deregulated environment also tends to be variable (and hence less predictable).

Thus, the power flow in a transmission line can vary even under normal, steady state conditions. The occurrence of a contingency (due to the tripping of a line, generator) can result in a sudden increase/decrease in the power flow. This can result in overloading of some lines and consequent threat to system security. A major disturbance can also result in the swinging of generator rotors which contribute to power swings in transmission lines. It is possible that the system is subjected to transient instability and cascading outages as individual components (lines and generators) trip due to the action of protective relays. If the system is operating close to the boundary of the small signal stability region, even a small disturbance can lead to large power swings and blackouts. The increase in the loading of the transmission lines sometimes can lead to voltage collapse due to the shortage of reactive power delivered at the load centers. This is due to the increased consumption of the reactive power in the transmission network and the characteristics of the load (such as induction motors supplying constant torque).

The factors mentioned in the above paragraph point to the problems faced in maintaining economic and secure operation of large interconnected systems. The problems are eased if sufficient margins (in power transformer) can be maintained. The required safe operating margin can be substantially reduced by the introduction of fast dynamic control over reactive and active power by high power electronic controllers. This can make the AC transmission network flexible' to adapt to the changing conditions caused by contingencies and load variations. Flexible AC Transmission System (FACTS) is used as Alternating current transmission systems incorporating power electronic-based and other static controllers to enhance controllability and increase power transfer capability. The FACTS controller is used as a power electronic based system and other static equipment that provide control of one or more AC transmission system parameters like voltage, current, power, impedance etc.

Benefits of utilizing FACTS devices: The benefits of utilizing FACTS devices in electrical transmission systems can be summarized as follows:

- Better utilization of existing transmission system assets.
- Increased transmission system reliability and availability.
- Increased dynamic and transient grid stability and reduction of loop flows.
- Increased quality of supply for sensitive industries.

5.2.2 FACTs controllers: Structures & Characteristics of following FACTs Controllers

The FACTS controllers can be classified as—

- Shunt connected controllers
- Series connected controllers
- Combined series-series controllers
- Combined shunt-series controllers

Depending on the power electronic devices used in the control, the FACTS controllers can be classified as-

A-Variable Impedance type controllers include:

- Static VAR Compensator (SVC), (shunt connected)
- Thyristor Controlled Series Capacitor or compensator (TCSC), (series connected)
- Thyristor Controlled Phase Shifting Transformer (TCPST)
- Static PST (combined shunt and series)

B-VSC based FACTS controllers are;

- Static synchronous Compensator (STATCOM) (shunt connected)
- Static Synchronous Series Compensator (SSSC) (series connected)
- Interline Power Flow Controller (IPFC) (combined series-series)
- Unified Power Flow Controller (UPFC) (combined shunt-series)

Some of the special purpose FACTS controllers are:

- Thyristor Controlled Braking Resistor (TCBR)
- Thyristor Controlled Voltage Limiter (TCVL)
- Thyristor Controlled Voltage Regulator (TCVR)
- Interphase Power Controller (IPC)

TCR

A shunt-connected, thyristor-controlled inductor whose effective reactance is varied in a continuous manner by partial-conduction control of the thyristor value. An elementary single-phase thyristor-controlled reactor (TCR) is shown in Fig. The current in the reactor can be controlled from maximum to zero by the method of firing delay angle control. That is the duration of the current conduction intervals is controlled by delaying the closure of the thyristor valve with respect to the peak of the applied voltage in each half-cycle. For $\alpha = 0^\circ$ the amplitude is at its maximum and for $\alpha = 90^\circ$ the amplitude is zero and no current is flowing during the corresponding half-cycle. Like this the same effect is provided as with an inductance of changing value.

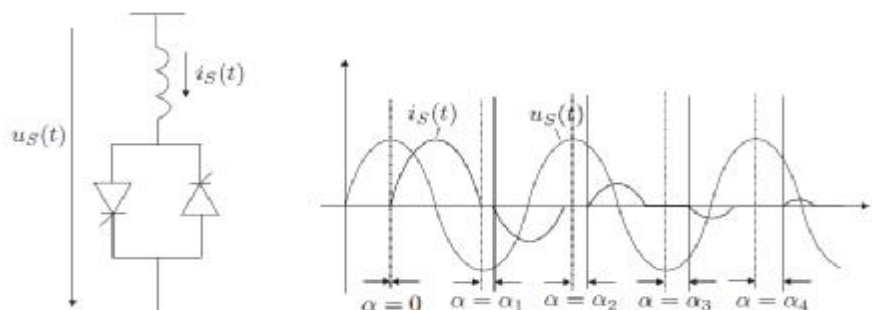

A thyristor switched reactor (TSR) has similar equipment to a TCR, but is used only at fixed angles of 90° and 180° , i.e. full conduction or no conduction. The reactive current $i_s(t)$ will be proportional to the applied voltage. Several TSRs can provide a reactive admittance controllable in a step-like manner.

Thyristor-Switched Capacitor (TSC)

A shunt-connected, thyristor-switched capacitor whose effective reactance is varied in a stepwise manner by full- or zero-conduction operation of the thyristor valve.

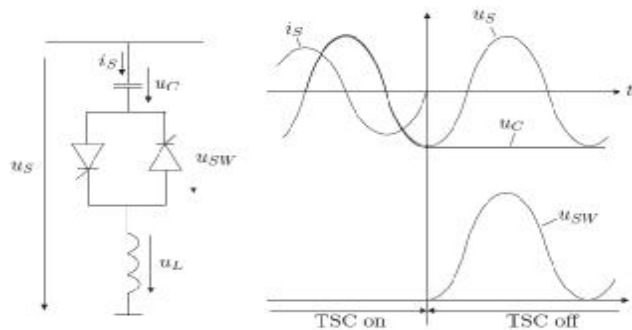

A single-phase thyristor-switched capacitor (TSC) is shown in fig. The TSC branch can be switched out at a zero crossing of the current. At this time instance the capacitor value has reached its peak value. The disconnected capacitor ideally stays charged at this peak value and the voltage across the non-conducting thyristor varies in phase with the applied ac voltage. Normally, the voltage across the capacitor does not remain constant during the time when the thyristor is switched out, but it is discharged after disconnection. To minimize transient disturbances when switching the TSC on, the reconnection has to take place at an instance where the AC voltage and the voltage across the conductor¹ Static Shunt Compensators are equal, that is when the voltage across the thyristor valve is zero. However, there will still be transients caused by the nonzero d_s/dt at the instant of switching, which without the reactor, would result an instant current in the capacitor ($i_s = C \cdot d_s/dt$). The interaction between the capacitor and the current (and d_s/dt) limiting reactor produces oscillatory transients on current and voltage. From these elaborations it follows that firing delay angle control is not applicable to capacitors; the capacitor switching must take place at that specific instant in each cycle at which the conditions for minimum transients are satisfied. For this reason, a TSC branch can provide only a step-like change in the reactive current it draws (maximum or zero).

Thus, the TSC is a single capacitive admittance which is either connected to or disconnected from the AC system. The current through the capacitor varies with the applied voltage. To approximate continuous current variations, several TSC branches in parallel may be used.

TCSC- Thyristor Controlled Series Capacitor

A TCSC is a capacitive reactance compensator, which consists of a series capacitor bank shunted by a thyristor controlled reactor in order to provide a smoothly variable series capacitive reactance.

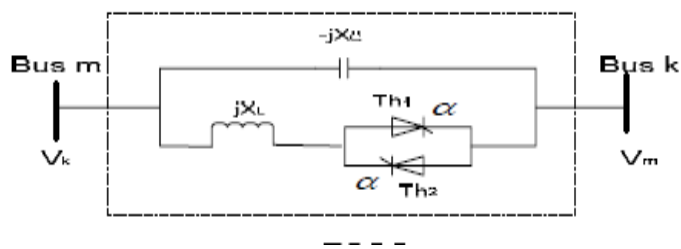

Even though a TCSC in the normal operating range is mainly capacitive, but it can also be used in an inductive mode. The power flow over a transmission line can be increased by controlled series compensation with minimum risk of sub-synchronous resonance (SSR). TCSC is a second generation FACTS controller, which controls the impedance of the line in which it is connected by varying the firing angle of the thyristors. A TCSC module comprises a series fixed capacitor that is connected in parallel to a thyristor controlled reactor (TCR). A TCR includes a pair of anti-parallel thyristors that are connected in series with an inductor. In a TCSC, a Metal Oxide Varistor (MOV) along with a bypass breaker is connected in parallel to the fixed capacitor for overvoltage protection. A complete compensation system may be made up of several of these modules.

TCSC controllers use thyristor-controlled reactor (TCR) in parallel with capacitor segments of series capacitor bank. The combination of TCR and capacitor allow the capacitive reactance to be smoothly controlled over a wide range and switched upon command to a condition where the bi-directional thyristor pairs conduct continuously and insert an inductive reactance into the line. TCSC is an effective and economical means of solving problems of transient stability, dynamic stability, steady state stability and voltage stability in long transmission lines. A TCSC is a series controlled capacitive reactance that can provide continuous control of power on the ac line over a wide range.

Thyristor Controlled Phase Angle Regulators (TCPAR) -

The TCPAR is equipment that can control power flow in transmission lines of power system by regulating the phase angle of the bus voltage. Flexible AC Transmission System (FACTS) controllers such as TCPAR play an important role in increasing load ability of the existing system and controlling the congestion in the network.

FACTS device like TCPAR can be used to regulate the power flow in the tie-lines of interconnected power system. When TCPAR is equipped with power regulator and frequency based stabilizer it can also significantly influence the power flow in the transient states occurring after power disturbances. In the case of simple interconnected power system, consisting of two power systems the control of TCPAR can force a good damping of both power swings and oscillations of local frequency. In the case of larger interconnected power system consisting of more than two power systems the influence of the control of TCPAR on damping can be more complicated.

Static Var Compensator (SVC)

Static var compensator is a static var generator whose output is varied so as to maintain or control specific parameters (e.g. voltage or reactive power of bus) of the electric power system.

In its simplest form it uses a thyristor controlled reactor (TCR) in conjunction with a fixed capacitor (FC) or thyristor switched capacitor (TSC). A pair of anti parallel thyristors is connected in series with a fixed inductor to form a TCR module while the thyristors are connected in series with a capacitor to form a TSC module. An SVC can control the voltage magnitude at the required bus thereby improving the voltage profile of the system. The primary task of an SVC is to maintain the voltage of a particular bus by means of reactive power compensation (obtained by varying the firing angle of the thyristors). It can also provide increased damping to power oscillations and enhance power flow over a line by using auxiliary signals such as line active power, line reactive power, line current, and computed internal frequency.

Static VAR Compensator (SVC) is a shunt connected FACTS controller whose main functionality is to regulate the voltage at a given bus by controlling its equivalent reactance. Basically it consists of a fixed capacitor (FC) and a thyristor controlled reactor (TCR).

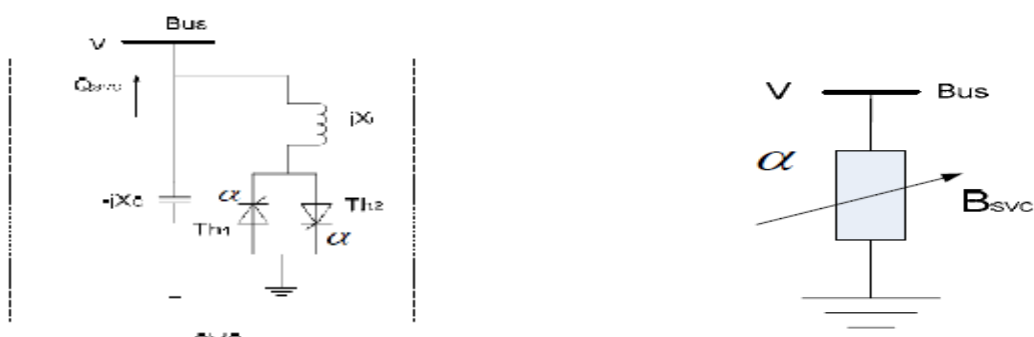

SVC firing angle model & SVC total susceptance model

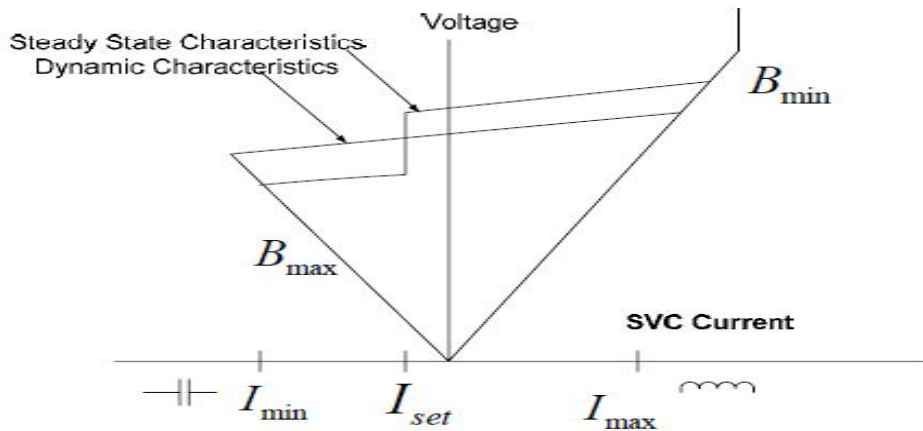

Steady-state and dynamic voltage/current Characteristics of the SVC

Static Synchronous Series Compensator (SSSC)

A SSSC is a static synchronous generator operated without an external electric energy source as a series compensator whose output voltage is in quadrature with, and controllable independently of the line current for the purpose of increasing or decreasing the overall reactive voltage drop across the line and thereby controlling the transmitted electric power. The SSSC may include transiently rated energy source or energy absorbing device to enhance the dynamic behaviour of the power system by additional temporary real power compensation, to increase or decrease momentarily, the overall real voltage drop across the line.

A SSSC incorporates a solid state voltage source inverter that injects an almost sinusoidal voltage of variable magnitude in series with a transmission line. The SSSC has the same structure as that of a STATCOM except that the coupling transformer of an SSSC is connected in series with the transmission line. The injected voltage is mainly in quadrature with the line current. A small part of injected voltage, which is in phase with the line current, provides the losses in the inverter. Most of injected voltage, which is in quadrature with the line current, emulates a series inductance or a series capacitance thereby altering the transmission line series reactance. This reactance, which can be altered by varying the magnitude of injected voltage,

favourably influences the electric power flow in the transmission line. SSSC is a solid-state synchronous voltage source employing an appropriate DC to AC inverter with gate turn-off thyristor. It is similar to the STATCOM, as it is based on a DC capacitor fed VSI that generates a three-phase voltage, which is then injected in a transmission line through a transformer connected in series with the system. In SSSC, the resonance phenomenon has been removed. So SSSC is having more superior performance as compare to TCSC. The main control objective of the SSSC is to directly control the current, and indirectly the power, flowing through the line by controlling the reactive power exchange between the SSSC and the AC system. The main advantage of this controller over a TCSC is that it does not significantly affect the impedance of the transmission system and, therefore, there is no danger of having resonance problem.

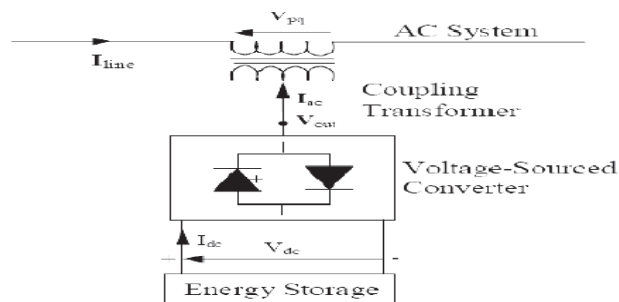

SSSC is a solid-state synchronous voltage source employing an appropriate DC to AC inverter with gate turn-off thyristor. It is similar to the STATCOM, as it is based on a DC capacitor fed VSI that generates a three-phase voltage, which is then injected in a transmission line through a transformer connected in series with the system. In SSSC, the resonance phenomenon has been removed. So SSSC is having more superior performance as compare to TCSC. The main control objective of the SSSC is to directly control the current, and indirectly the power, flowing through the line by controlling the reactive power exchange between the SSSC and the AC system. The main advantage of this controller over a TCSC is that it does not significantly affect the impedance of the transmission system and, therefore, there is no danger of having resonance problem.

Static Synchronous Compensator (STATCOM)

A STATCOM is a static synchronous generator operated as a shunt connected static var compensator whose capacitive or inductive output current can be controlled independent of the ac system voltage.

A STATCOM is a solid state switching converter capable of generating or absorbing independently controllable real and reactive power at its output terminals, when it is fed from an energy source or an energy storage device of appropriate rating. A STATCOM incorporate a voltage source inverter (VSI) that produces a set of three phase ac output voltages, each of

which is in phase with, and coupled to the corresponding ac system voltage via a relatively small reactance. This small reactance is usually provided by the per phase leakage reactance of the coupling transformer. The VSI is driven by a dc storage capacitor. By regulating the magnitude of the output voltage produced, the reactive power exchange between STATCOM and the ac system can be controlled. The Static Synchronous Compensator (STATCOM) is a power electronic-based Synchronous Voltage Generator (SVG) that generates a three-phase voltage from a dc capacitor in synchronism with the transmission line voltage and is connected to it by a coupling transformer.

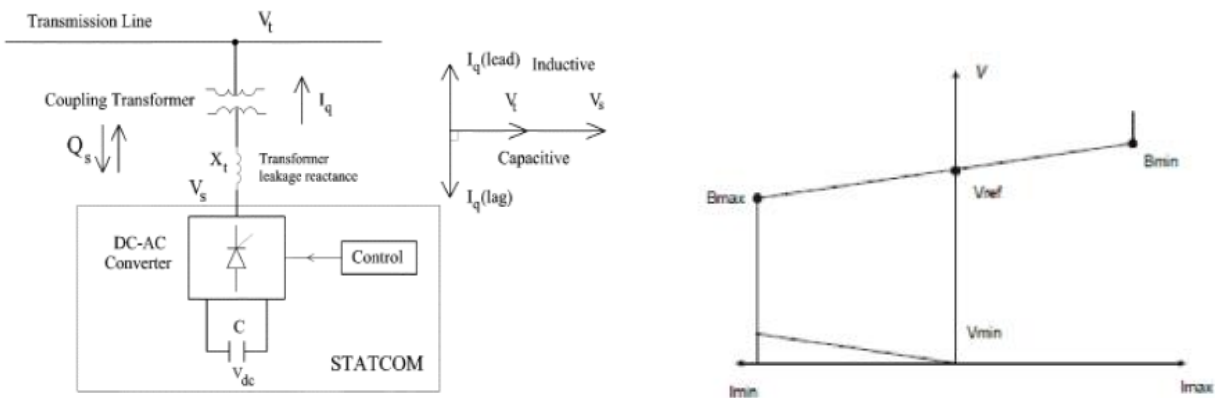

By controlling the magnitude of the STATCOM voltage the reactive power exchange between the STATCOM and the transmission line and hence the amount of shunt compensation can be controlled. The following mode of operation of STATCOM given as:

1. Over excited mode of operation
2. Under excited mode of operation
3. Normal (floating) mode of operation

In STATCOM, the resonance phenomenon has been removed. So STATCOM is having more superior performance as compared to SVC.

Unified Power Flow Controller(UPFC)-

The UPFC, by means of angularly unconstrained series voltage injection, is able to control, concurrently or selectively, the transmission line voltage, impedance, and angle or, alternatively, the real and reactive power flow in the line. The UPFC may also provide independently controllable shunt reactive compensation.

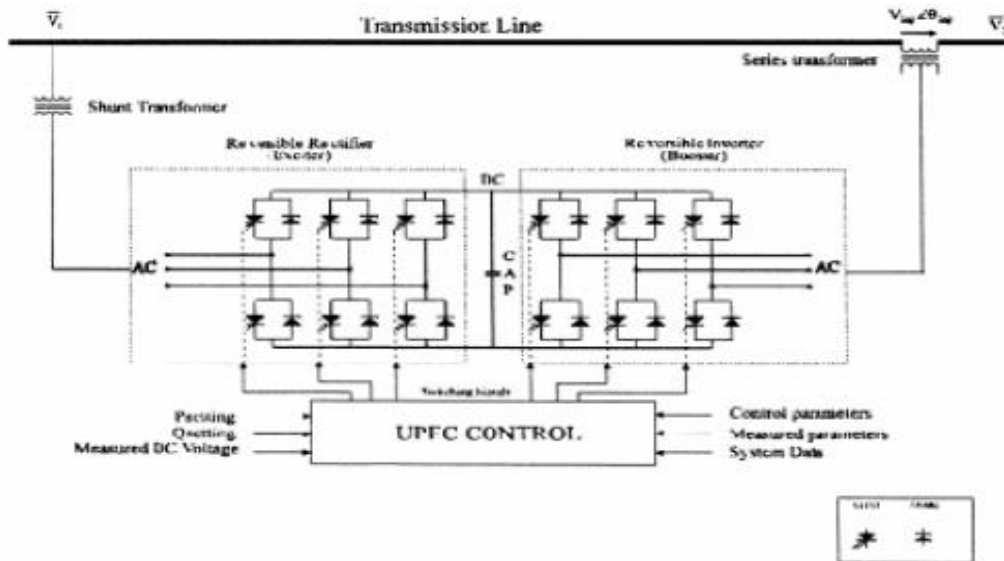

The UPFC is the most versatile and powerful FACTS device. UPFC is also known as the most comprehensive multivariable flexible ac transmission system (FACTS) controller. Simultaneous control of multiple power system variables with UPFC poses enormous difficulties. In addition, the complexity of the UPFC control increases due to the fact that the controlled and the variables interact with each other. The Unified Power Flow Controller (UPFC) is used to control the power flow in the transmission systems by controlling the impedance, voltage magnitude and phase angle. This controller offers advantages in terms of static and dynamic operation of the power system. The basic structure of the UPFC consists of two voltage source inverter (VSI); where one converter is connected in parallel to the transmission line while the other is in series with the transmission line. The UPFC consists of two voltage source converters; series and shunt converter, which are connected to each other with a common dc link. Series converter or Static Synchronous Series Compensator (SSSC) is used to add controlled voltage magnitude and phase angle in series with the line, while shunt converter or Static Synchronous Compensator (STATCOM) is used to provide reactive power to the ac system, beside that, it will provide the dc power required for both inverter. Each of the branch consists of a transformer and power electronic converter. These two voltage source converters share a common dc capacitor. The energy storing capacity of this dc capacitor is generally small. Therefore, active power drawn by the shunt converter should be equal to the active power generated by the series converter. The reactive power in the shunt or series converter can be chosen independently, giving greater flexibility to the power flow control. The coupling transformer is used to connect the device to the system.

Thyristor-Switched Series Capacitor (TSSC)

The basic element of a TSSC is a capacitor shunted by bypass valve. The capacitor is inserted into the line if the corresponding thyristor valve is turned off, otherwise it is bypassed.

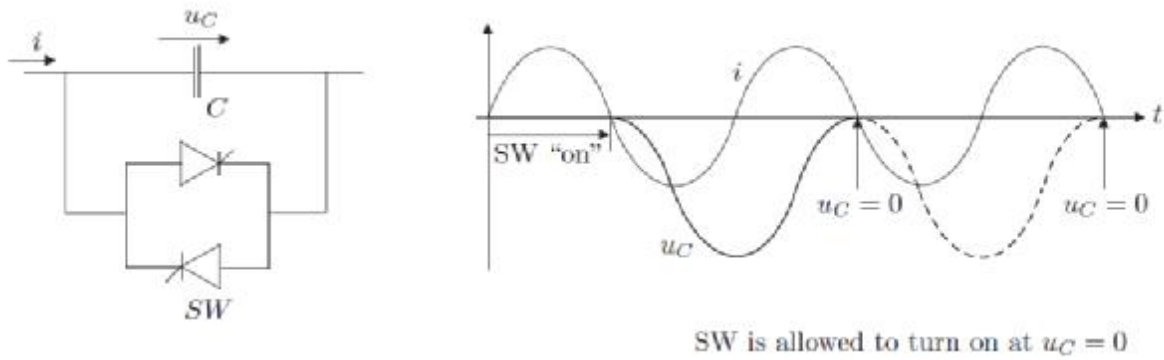

A thyristor valve is turned off at the instance when the current crosses zero. Thus, the capacitor can be inserted into the line by the thyristor valve only at the zero crossings of the line current. On the other hand, the thyristor valve should be turned on for bypass only when the capacitor voltage is zero in order to minimize the initial surge current in the valve, and the corresponding circuit transient. This results in a possible delay up to one full cycle to turn the valve on. Therefore, if the capacitor is once inserted into the line, it will be charged by the line current from zero to maximum during the first half-cycle and discharged from maximum to zero during the successive half-cycle until it can be bypassed again.

A Thyristor-Switched Series Capacitor is built from several of these basic elements in series. The degree of series compensation is controlled in a step-like manner by increasing or decreasing the number of series capacitors inserted. Thus, a TSSC can only provide discrete capacitor values for series compensation. A TSSC can be applied for power flow control and for damping power oscillations.

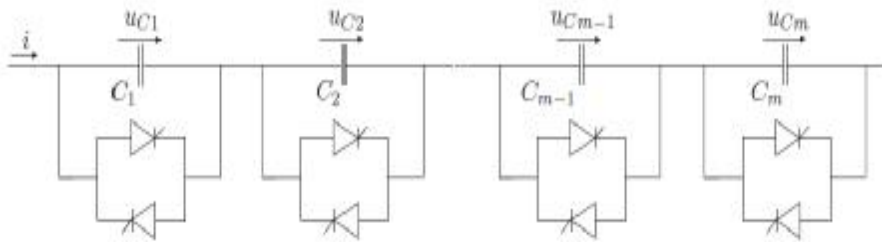

Thyristor-Switched Series Capacitor